



SPRAY NOZZLES FOR INDUSTRIAL APPLICATIONS



**INDUSTRIAL
TANK WASHING
SYSTEMS**



PNR ITALIA

SPRAY NOZZLES FOR INDUSTRIAL APPLICATIONS

PNR ITALIA manufactures and markets small spraying nozzles for individual use up to spraying systems for large industrial plants and is able to meet every customer's need with targeted solutions.

The wide range of products includes spray nozzles, washing heads and complementary accessories such as filters, guns and hoses for industrial washing, ejectors, blow nozzles, joints and hose clamps.

Located in Voghera, not far from Milan, the Headquarter and production plant is located in a strategic area favored by the proximity to the main motorway networks and important international maritime routes, easily accessible from the port of Genoa.

PNR ITALIA started its activity in 1968 with the trade and production of components and spraying nozzles for fire protection systems and, subsequently, with a range of sprayers for industrial applications. Over time it has grown and consolidated through a commercial policy based on a widespread network of partners present in the main foreign markets and also thanks to a continuous investment in research.

Today PNR ITALIA has at its disposal a technologically advanced production plant for the production of spraying nozzles, washing heads and atomizers with absolute quality machines, many of which work with CNC technology, often internally designed for special machining.

With an annual production of about 9 million pieces, PNR ITALIA is a solid industrial reality oriented to constant growth, driven by high-tech investments and product innovation.



CONTENT

2	TANK WASHING TECHNIQUES
4	APPLICATIONS
6	FIXED SPRAY HEADS
12	SINGLE AXIS HEADS
13	REACTION DRIVE
19	MOTOR DRIVE
21	TWIN AXIS HEADS
23	AUXILIARY WASHING EQUIPMENTS
25	HIGH-PRESSURE HEADS
28	SPECIAL PRODUCTS
32	SANITARY PRODUCTS
34	SUMMARY TABLE
35	TECHNICAL INFORMATION
36	GENERAL INFORMATION



PNR Italia Headquarter, Voghera (Italy)

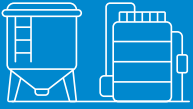

TANK WASHING TECHNIQUES

The continuous research for higher efficiency in all kind of industries, and the requirement to assure a constant and higher quality level for their products, highlight the necessity that every step in the production, stocking and transporting processes are performed using adequately clean systems and tanks.

At the same time, as disposing of liquid effluents is becoming more and more costly, it becomes necessary that each cleaning process, while reaching a totally satisfactory result, is performed using the lowest possible volume of cleaning solution.

The two above factors have originated the introduction on the market of an always wider variety of tank cleaning devices, ranging from the classic fixed head to more and more sophisticated models to cope with the most demanding applications.

Our long experience in the field of tank cleaning suggests that the following basic concepts are given proper consideration in order to determine the correct washing cycle for each single application, and consequently the most suitable type of tank cleaning device.

1 PROPER FILTERING FOR THE WASHING LIQUID

Small inner passages and precision machined parts are typically found in tank washing equipment. In such cases where the washing cycle is performed by means of a recycled solution the solid particles which may be dispersed into the solution must be characterized for dimension and properties. Since suspended solid particles may affect proper operation of tank washing equipment, or require more frequent cleaning or service of the same, we suggest that a suitable line filter be considered.

2 CORRECT CHOICE FOR WASHING CYCLE AND SOLUTION

Based on the type of product which has to be eliminated, each single process has to be examined in order to define such parameters as the appropriate washing fluid, the right temperature, jet pressure and washing time of every phase.

3 ADEQUATE MOTIVE MECHANISM

The number of products which need to be removed from the wall of a tank is near to endless, each one showing its own different properties. Washing cycles can range from a quick water rinse at low pressure and ambient temperature, to long lasting cycles using hot water and caustic, sometimes at high pressure. The latter situation requires both a slow motion of the fluid jets, which have to hit the tank wall without breaking into drops and loose their impact, and a properly indexed rotation so that the revolving jets do not hit the same path at each turn.

Our tankwashers range, the most complete on the market, is classified by number of rotation axis and type of motive mechanism.

4 CLEANING RADIUS / WETTING RADIUS

It is not possible to define the cleaning radius of any tank washing equipment without making reference to precise conditions as the product to be eliminated, the cleaning fluid, the operating pressure and temperature.

Such value can only be determined by experience, for each single given process. It is instead possible to define a wetting radius, as the radius where the equipment can wet the entire tank inner surface: in this condition it must be expected the fluid to hit the wall with a small fraction of its original impact force.

We are available to put our experience at your service, and advise you in choosing the equipment that best suits your needs.

CONSTRUCTION MATERIALS

Because of their application in the chemical, food and pharmaceutical processes tankwashers are manufactured as a rule out of high quality materials, offering in various combinations high resistance to corrosion and ability to withstand high temperatures. Metal parts are usually made of austenitic stainless steel, mostly AISI 316L and AISI 316Ti grades, while some special applications may require high grade alloys like Hastelloy, in a variety of types. Parts in plastic materials are normally made out Teflon, Graphite-filled Teflon or PEEK.

EFFICIENCY ASSESSMENT

It is very difficult to assess such value as the efficiency range with reference to a given tank washing device without taking into considerations the various parameters relating to the process conditions, such as the materials you have to remove, working temperature and pressure, the time of every washing cycle.

While choosing a tank washing head, you have to consider if:

- the wetting radius is adequate for the dimension of the tank
- the capacity can provide the whole inner surface with a correct amount of washing solution for square measure;
- the impact force of the jet and the time required to complete a cleaning cycle are adequate for the product and/or process.

While taking in consideration all these elements, PNR Italia can suggest one or more suitable tank washing heads, depending on the specific case.

CLEANING VALIDATION

This is the process whereby the desired cleaning condition is verified by means of a repeatable technique supplying results easily readable and according to the quality control requirements. There are two main verification you can do, in order to have a correct validation:

ADEQUATE DISTRIBUTION OF THE SPRAY ON THE SURFACE OF THE TANK

It's common to spray the inner surface of the tank with Riboflavin, then to complete a cleaning cycle, and therefore to examine with an ultraviolet lamp that every trace of Riboflavin has been eliminated. Riboflavin is easily miscible with water at ambient temperature and should be completely eliminated from the surface when the same is satisfactorily covered by the washing jets. Traces of Riboflavine still sticking to the surface are revealed through an ultra-violet long wave light, and indicate areas not properly covered from the washing operation.

ABSENCE OF ORGANIC RESIDUE

Cleaning operations tend to eliminate proteins spots of animal/vegetable origin, nourishment for microorganisms that facilitate the development of bacteria and retrain active molecules. The variety of possible cases and of existing regulations is such that the validation methodology is examined on a case-by-case basis. For example, a very common the technique is ATP-metry to count bacteria, which is based on ATP (Adenosine triphosphate, source of energy present in all living cells): the degradation reaction of ATP produces photons, whose intensity it is proportional to the amount of ATP present, and therefore the measurement of luminous intensity with a luminometer gives information on the quantity of cells present, and therefore on the cleaning condition of the tank.

DEFINITIONS

SPRAY COVERAGE

It is the solid angle covered by the jets, with an origin in the point of the tank washer at the water inlet, and defined as follows:

- the reference direction is the one of the fluid in the inlet connection;
- the direction of the jet is DOWN when it is concurrent to the reference direction;
- the direction of the jet is UP when it is opposite to the reference direction.

SINGLE AXIS HEADS

It's a device where the moving part is rotating around the vertical axis of the feed pipe.

They are more suitable to wash products with low resistance.

TWIN AXIS HEADS











It's a device where the washing nozzles rotate around an horizontal axis, while the tankwasher body carrying the nozzles rotates at the same time around the vertical axis of the feed pipe. They allow stronger washing actions.

FDA APPROVED

With this sentence, we confirm that the materials used for manufacturing the products fall within the list of the FDA and CE 1935/2004 approved food grade materials.

Among them we have AISI 316L, PTFE, PEEK.

WASHING HEADS APPLICATIONS

	INDUSTRY	RESIDUES CLEANED
	CHEMICAL, PAINTS & COATINGS	PAINTS PLASTICS RESINS ADHESIVES SEALANTS LATEX ACRYLICS
	FOOD PROCESSING	DAIRY JUICES SAUCES SUGARS SOUPS FROZEN FOOD INGREDIENTS
	PHARMACEUTICAL	MEDICINES POWDERS ACTIVE INGREDIENTS
	PULP & PAPER	PAPER STOCK INKS COLORS
	ETHANOL	YEAST SLURRY CORN MASH
	PERSONAL CARE	SHAMPOO LOTION CRÈMES OILS COSMETICS PERFUMES
	WINERIES	WINE SPICES SUGARS
	BREWERIES	MALT YEAST MASH WORT BEER
	TRANSPORTATION	ORANGE JUICE DAIRY PRODUCTS FOOD INGREDIENTS OIL CHEMICALS
	SHIPBUILDING	ORGANIC SEWAGE SEAWEED

EQUIPMENT TYPES		TANK CLEANING HEADS USED			
MIXERS/BLENDERS REACTORS PROCESS TANKS	STORAGE TANKS TOTES DRUMS	UBB UBT	UKD UKR		
COOKERS/FRYERS STORAGE TANKS RAIL CARS	KETTLES MIXERS/BLENDERS SPRAY DRY TOWERS	UA3 UA0 UBB	UBC UBD	UBF UBT UBX	UKD UKK UKR
BLENDERS FERMENTERS TOTES/DRUMS	STORAGE CONTAINERS SPRAY DRY TOWERS	UA0 UAC UBA	UBB UBC UBD	UBF UBT UBX	UKD UKR
BROKE CHESTS STOCK CHESTS TOTES/CONTAINERS TANK TRAILERS		UBA UBB	UBC UBE	UBT CH	
FERMENTERS YEAST TANKS STORAGE TANKS TANK TRAILERS		UBT			
MIXERS BLENDERS KETTLES	DRYERS VESSELS STORAGE TANKS	UBB UBC UBT	UKD UKR		
FERMENTERS BARRELS KEGS WINE STORAGE		UA3 UBB	UBF UBT	UKD UKK UKR	
FERMENTERS BREW KETTLES MASH TANKS	STORAGE TANKS HOT WORT RECEIVERS	UBT UBX	UKD UKK UKR		
WET/DRY BULK TRANSPORT TRAILERS RAIL CARS TOTES	IBC'S ISO TANKS/CONTAINERS	UBT UBQ	UKD UKR	UKD UKR	
BLACK CHAMBER WASHING TANK PURIFICATION TANK SANITATION		UBC			

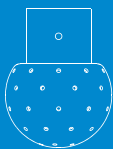

FIXED SPRAY HEADS

The most simple tank washing devices, fixed heads or spray balls are the classic equipment used in thousands of tanks for their reliability and since easily kept in perfect hygienic conditions.

Their low impact properties and high volume fluid requirement limit their use to small tank sizes and processes where easily cleaned liquids and non sticking products have to be eliminated.

Our models UA3, UAB and UAC are made out of high quality stainless steel and cover most possible applications, while we are still pleased to quote for special models designed on individual requirements.



ANGLES COVERAGE

The coverage angles mentioned in this Catalog are intended for fixed or rotating balls mounted on the top of the tank and spraying downwards. Therefore when we speak of UP and DOWN we always mean jets directed towards the upper and lower parts of the tank with the washing device mounted on the upper part of the tank. The letter indicating the coverage angle value is the penultimate of the product code.

CONNECTIONS SIZE

Washing devices are often supplied with clip connections that make disassembly operations quick and easy to clean the component, alternatively they are also available in the version with solder connection.

UA3

UA3 tank washing heads are the most advanced hygienic devices available for applications in food industry. Designing and realization follow 3-A Sanitary Standard. The electropolishing finish assures a roughness Ra < 0,8 µm required for the devices used in food processing. Used materials follow standard EC 1935/2004 and come under the list of materials indicated by FDA for food application.

MATERIAL: B31 AISI 316L STAINLESS STEEL

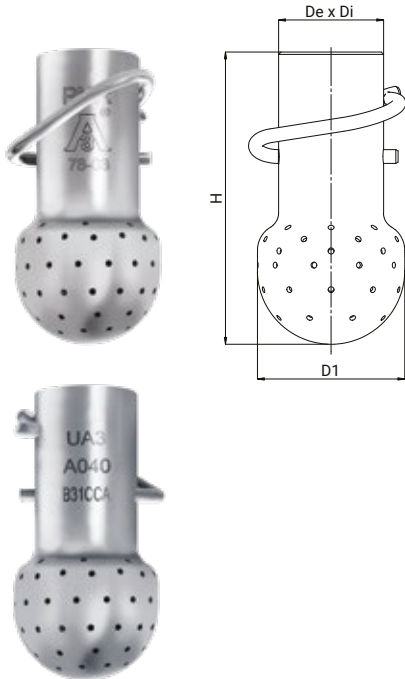

CODE	Connection	Connection pipe	D1	Capacity	Coverage	Dia	H	WR
	De x Di (mm x mm)	Standard DIN 11866						
UA3 A040 B31ACA	22,8 x 19,8	DN 15 File A	32	4,00	180°UP	1,3	63,5	1,7
UA3 C056 B31ACA	32,8 x 29,8	DN 25 File A	50	5,60		2,0	100	2,2
UA3 D098 B31ACA	44,8 x 41,8	DN 40 File A	65	9,80		2,5	117	2,7
UA3 A040 B31BCA	22,8 x 19,8	DN 15 File A	32	4,00	180°DOWN	1,3	63,5	2,0
UA3 C056 B31BCA	32,8 x 29,8	DN 25 File A	50	5,60		2,0	100	2,5
UA3 D098 B31BCA	44,8 x 41,8	DN 40 File A	65	9,80		2,5	117	3,0
UA3 A040 B31CCA	22,8 x 19,8	DN 15 File A	32	4,00	270°UP	1,3	63,5	1,5
UA3 C056 B31CCA	32,8 x 29,8	DN 25 File A	50	5,60		2,0	100	2,0
UA3 D098 B31CCA	44,8 x 41,8	DN 40 File A	65	9,80		2,5	117	2,5
UA3 A026 B31ECA	22,8 x 19,8	DN 15 File A	32	2,60	360°	1,3	63,5	1,0
UA3 C056 B31ECA	32,8 x 29,8	DN 25 File A	50	5,60		2,0	100	1,5
UA3 D193 B31ECA	44,8 x 41,8	DN 40 File A	65	19,3		2,5	117	2,0

Read more about 3-A certification at the end of the catalog.

UAB

UAB heads are very compact devices, for applications like pipe washing or for cleaning tight spaces. The thick walls of this device, which is machined from solid stainless steel rod, make it also a good choice where the washing process needs to be performed at high pressure values.

MATERIAL: B1 AISI 303 STAINLESS STEEL
B31 AISI 316L STAINLESS STEEL

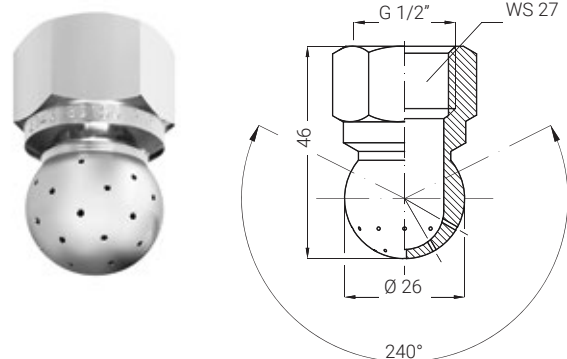

BSP thread

CODE	Dia mm	D mm	Capacity at different pressure values			
			2,0	3,0	4,0	5,0
UAB 2220 xxSG	0,8	26	18,0	22,0	25,3	28,5
UAB 2343 xxSG	1,0		28,0	34,3	39,5	44,3
UAB 2700 xxSG	1,5		57,0	70,0	80,5	90,3
UAB 3110 xxSG	2,0		90,0	110	126	142
UAB 3145 xxSG	2,3		118	145	167	187

UAC

UAC fixed spray heads are a simple, fast and efficient device for cleaning the inside of small size tanks where a simple rinsing action is required. Because of the relatively high washing fluid flow rate, they are usually operated at low pressures and can achieve a limited impact action on the tank wall. Their simple design allows for the head to be easily cleaned after being operated, which makes it possible to leave the heads permanently in place ready for use. The values for wetting radiuses shown at the right of the table have been obtained operating the heads with a water pressure value of 1 bar. On request, heads with electropolishing $Ra < 0,8 \mu m$ are available, in order to have roughness for alimentary applications.

MATERIAL: 31 AISI 316L STAINLESS STEEL CONNECTION: FEMALE THREAD (BSPP - NPT);
 L8 HASTELLOY C267 (ON REQUEST) CLIP-ON; WELDED.
 H1 TITANIUM GR2 (ON REQUEST)

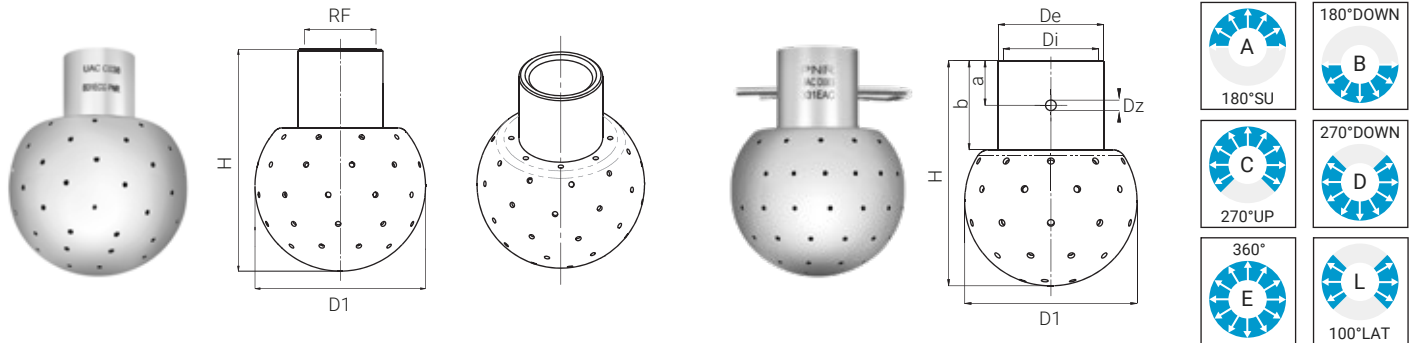

CODE											Capacity at different pressures (bar)					WR m															
SERIES	Size available (mm)					Capacity code	Mat.	Coverage			Thread dimension		Connection		0,5 l/min		1,0 m³/h	1,0 l/min	2,0 l/min	3,0 l/min											
	D1	A	B	C	D			E	RF	RF	RF	RF	Threaded	Clip-on / Welded																	
							AISI 316L	180° up	180° down	270° up	270° down	360°	100° lat	1/8"	1/4"	3/8"	1/2"	3/4"	1"	1-1/4"	Clip / Welded	BSPP	NPT	Clip-on	Welded						
	(Clip)	a	8	9,5	11,5	15	19																								
		b	16	21	23	30	38																								
		Dz	2,2	2,5	2,5	2,8	3,3																								
UAC								012	B31	A	B	C*	D*	E*	L*							G	N	C	W	14,0	1,20	20,0	28,0	35,0	0,5
UAC	A							014	B31	A	B	C*	D*	E*	L*	A						G	N	C	W	16,0	1,40	23,3	33,0	40,0	0,8
UAC								018	B31	A	B	C*	D*	E*	L*							G	N	C	W	21,0	1,80	30,0	42,0	54,0	0,8
UAC								021	B31	A	B	C*	D*	E*	L*							G	N	C	W	25,0	2,10	35,0	50,0	61,0	1,0
UAC								031	B31	A	B	C	D	E	L							G	N	C	W	37,0	3,10	51,7	73,0	90,0	1,1
UAC								038	B31	A	B	C	D	E	L	B						G	N	C	W	45,0	3,80	63,3	90,0	110	1,2
UAC	B							047	B31	A	B	C	D	E	L							G	N	C	W	55,0	4,70	78,3	111	136	0,9
UAC								054	B31	A	B	C	D	E	L	C						G	N	C	W	64,0	5,40	90,0	127	156	1,0
UAC								063	B31	A	B	C	D	E	L							G	N	C	W	74,0	6,30	105	149	182	1,2
UAC								072	B31	A	B	C	D	E	L							G	N	C	W	85,0	7,20	120	170	208	1,3
UAC								078	B31	A	B	C	D	E	L							G	N	C	W	92,0	7,80	130	184	225	1,5
UAC								086	B31	A	B	C	D	E	L	D						G	N	C	W	101	8,60	143	203	248	1,6
UAC								092	B31	A	B	C	D	E	L							G	N	C	W	108	9,20	153	217	266	1,6
UAC								102	B31	A	B	C	D	E	L							G	N	C	W	120	10,2	170	240	295	1,7
UAC								110	B31	A	B	C	D	E	L							G	N	C	W	130	11,0	183	250	318	1,8
UAC								123	B31	A	B	C	D	E	L							G	N	C	W	145	12,3	205	290	355	1,8
UAC								132	B31	A	B	C	D	E	L							G	N	C	W	155	13,2	220	310	381	1,9
UAC								157	B31	A	B	C	D	E	L							G	N	C	W	185	15,7	262	370	453	2,0
UAC								160	B31	A	B	C	D	E	L							G	N	C	W	190	16,0	267	277	462	2,0
UAC								175	B31	A	B	C	D	E	L							G	N	C	W	207	17,5	292	413	505	2,1
UAC								209	B31	A	B	C	D	E	L							G	N	C	W	246	20,9	348	492	603	2,4
UAC								217	B31	A	B	C	D	E	L							G	N	C	W	256	21,7	362	512	627	2,5
UAC								228	B31	A	B	C	D	E	L							G	N	C	W	270	22,8	380	537	660	2,7
UAC								242	B31	A	B	C	D	E	L							G	N	C	W	285	24,2	403	570	700	2,8
UAC								286	B31	A	B	C	D	E	L							G	N	C	W	337	28,6	477	675	825	3,0
UAC								321	B31	A	B	C	D	E	L							G	N	C	W	380	32,1	535	755	925	3,1
UAC								371	B31	A	B	C	D	E	L							G	N	C	W	437	37,1	618	875	1070	3,2
UAC								431	B31	A	B	C	D	E	L							G	N	C	W	510	43,1	718	1015	1245	3,4
UAC								491	B31	A	B	C	D	E	L							G	N	C	W	580	49,1	818	1160	1412	3,5

Letters marked with * in "Spray coverage" section state that those models are not available for "Thread Dimension" = 1/8" (letter A)

UAC

HOW TO CREATE THE COMPLETE CODE

SERIES	Size available (mm)					Capacity code	Mat.	Spray coverage						Thread dimension					Connection			Capacity at different pressures (bar)					WR		
	A	B	C	D	E			180° up	180° down	270° up	270° down	360°	100° lat	RF					Clip / Welded	Threaded			0,5	1,0	1,0	2,0		3,0	
	D1	H	a	b	Dz			1/8"	1/4"	3/8"	1/2"	3/4"	1"	1-1/4"	BSP	NPT	Clip-on	Welded		l/min	m³/h	l/min	l/min	l/min					
UAC			C			063	B31	A	B	C	D	E	L							G	N	C	W	74,0	6,30	105	149	182	1,2
UAC			C			072	B31	A	B	C	D	E	L							G	N	C	W	85,0	7,20	120	170	208	1,3
UAC			C			078	B31	A	B	C	D	E	L							G	N	C	W	92,0	7,80	130	184	225	1,5

Complete code **UAC C072 B31DEG**

Series	UAC	Fixed spray head
Size	C	Diameter 50 mm
Capacity code	072	7,2 [m³/h] @ 1bar
Material	B31	AISI 316L
Spray coverage	D	270° down
Thread dimension	E	3/4"
Connection	G	BSP

CLIP-ON AND WELDED CONNECTION SIZE

In 2016, Standard DIN 11866 gathered some of the most important standards regarding inox pipes. Some of our products can already couple to pipes respondent to these standards. Pipes with dimensions in compliance with obsolete standards are very common, therefore they are still produced without problems by PNR Italia. We are also available to guarantee the connection with every pipe that has a thickness within the standard values.

In the following table you can find the dimension we can provide.

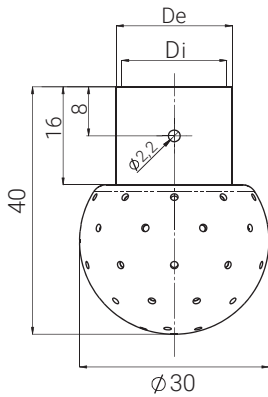

Type A Ø30mm

	CLIP-ON		WELDED	
	(De x Di)	Pipe	(De x Di)	Pipe
A	Ø 20 x 18	/	/	/
B	Ø 22 x 20	/	Ø 13,7 x 9,2	ASTM A 213 1/4" 40S
C	Ø 14,5 x 12,5	DN10 - DIN 11850/1	Ø 17,1 x 12,4	ASTM A 213 3/8" 40S
D	Ø 15,5 x 13,5	DN10 - DIN 11886/A	Ø 12 x 10	DN10 - DIN 11886/1
E	Ø 20,5 x 18,5	/	Ø 13 x 10	DN10 - DIN 11886/A
F	Ø 16,2 x 14,2	ASTM A 213 1/4"	Ø 18 x 16	DN15 - DIN 11850/1
J	Ø 19,6 x 17,6	ASTM A 213 3/8"	Ø 19 x 16	DN15 - DIN 11886/A
H	Ø 12 x 10	DN10 - DIN 11886/C	Ø 6,35 x 4,55	DN8 - DIN 11886/C

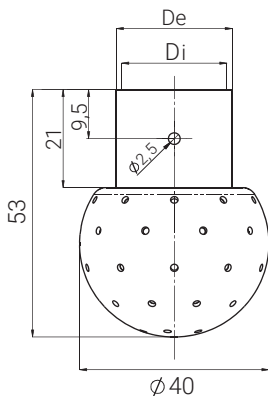

Type B Ø40mm

	CLIP-ON		WELDED	
	(De x Di)	Pipe	(De x Di)	Pipe
A	Ø 20 x 18	/	Ø 18 x 16	DN15 - DIN 11850/1
B	Ø 22 x 20	/	Ø 19 x 17	DN15 - DIN 11886/A
C	Ø 24,5 x 22,5	DN10 - DIN 11850/1	Ø 17,1 x 12,4	ASTM A 213 3/8" 40S
D	Ø 25,5 x 23,5	DN20 - DIN 11886/A	Ø 21,3 x 15,8	ASTM A 213 1/2" 40S
E	Ø 16,2 x 14,2	ASTM A 213 1/4"	Ø 22 x 20	DN20 - DIN 11850/1
F	Ø 19,6 x 17,6	ASTM A 213 3/8"	Ø 23 x 20	DN20 - DIN 11886/A
G	Ø 23,8 x 21,8	DN15 - DIN 11886/B	Ø 25,4 x 22,2	DN25 - DIN 11886/C

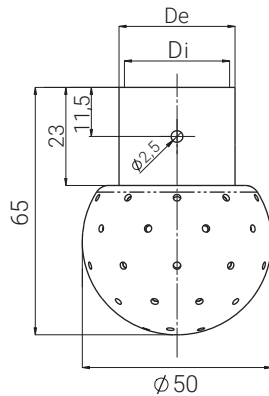

Type C Ø50mm

	CLIP-ON		WELDED	
	(De x Di)	Pipe	(De x Di)	Pipe
A	Ø 24,5 x 22,5	DN15 - DIN 11886/B	Ø 22 x 20	DN20 - DIN 11850/1
B	Ø 25,5 x 23,5	DN20 - DIN 11886/A	Ø 23 x 20	DN20 - DIN 11886/A
C	Ø 23,8 x 21,8	DN15 - DIN 11886/B	Ø 21,3 x 15,8	ASTM A 213 1/2" 40S
D	Ø 28 x 26	DN25 - DIN 11886/C	Ø 26,7 x 20,9	ASTM A 213 3/4" 40S
E	Ø 30,2 x 28,2	DN25 - DIN 11886/B	Ø 29 x 26	DN25 - DIN 11850/1
F	Ø 22 x 20	/	Ø 25,4 x 22,2	DN25 - DIN 11886/A
G			Ø 28 x 26	DN25 - DIN 11886/C

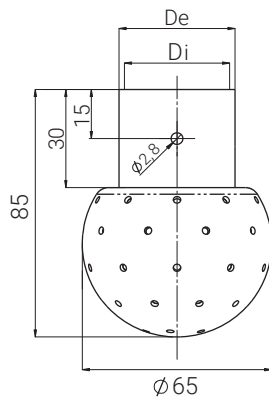

Type D Ø65mm

	CLIP-ON		WELDED	
	De x Di	Pipe	De x Di	Pipe
A	Ø 30,5 x 28,5	DN25 - DIN 11850/1	Ø 28 x 26	DN25 - DIN 11850/1
B	Ø 31,5 x 29,5	DN25 - DIN 11886/A	Ø 29 x 26	DN25 - DIN 11886/A
C	Ø 36,5 x 34,5	DN32 - DIN 11850/1	Ø 34 x 32	DN32 - DIN 11850/1
D	Ø 28 x 26	DN25 - DIN 11886/C	Ø 35 x 32	DN32 - DIN 11886/A
E	Ø 32 x 30	/	Ø 26,7 x 20,9	ASTM A 213 3/4" 40S
F	Ø 38 x 36	/	Ø 33,4 x 26,6	ASTM A 213 1" 40S
G	Ø 37,5 x 35,5	DN32 - DIN 11886/A	Ø 40 x 38	DN40 - DIN 11850/1
H	Ø 42,5 x 40,5	DN40 - DIN 11850/1	Ø 41 x 38	DN40 - DIN 11886/A
I	Ø 29,2 x 27,2	ASTM A 213 3/4"		
J	Ø 35,9 x 33,9	ASTM A 213 1"		

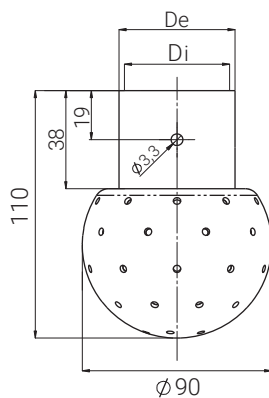

Type E Ø90mm

	CLIP-ON		WELDED	
	De x Di	Pipe	De x Di	Pipe
A	Ø 36,5 x 34,5	DN32 - DIN 11850/1	Ø 34 x 32	DN32 - DIN 11850/1
B	Ø 37,5 x 35,5	DN32 - DIN 11886/A	Ø 35 x 32	DN32 - DIN 11886/A
C	Ø 42,5 x 40,5	DN40 - DIN 11850/1	Ø 40 x 38	DN40 - DIN 11850/1
D	Ø 43,5 x 41,5	DN40 - DIN 11886/A	Ø 41 x 38	DN40 - DIN 11886/A
E	Ø 32 x 30	/	Ø 52 x 50	DN50 - DIN 11850/1
F	Ø 38 x 36	/	Ø 33,4 x 26,6	ASTM A 213 1" 40S
G	Ø 54,5 x 52,5	DN50 - DIN 11850/1	Ø 42,2 x 35	ASTM A 213 1-1/4" 40S
H	Ø 55,5 x 53,5	DN50 - DIN 11886/A	Ø 48,2 x 40,9	ASTM A 213 1-1/2" 40S
I	Ø 35,9 x 33,9	ASTM A 213 1"	Ø 60,3 x 52,5	ASTM A 213 2" 40S
J	Ø 44,7 x 42,7	ASTM A 213 1-1/4"	Ø 53 x 50	DN50 - DIN 11886/A
K	Ø 50,8 x 48,8	ASTM A 213 1-1/2"	Ø 38,1 x 34,9	DN40 - DIN 11886/C
L	Ø 62,8 x 60,8	ASTM A 213 2"		

CH

CH series includes large and small capacities full cone cluster nozzles. They make a cluster spray pattern and are available in 7 and 13 nozzles versions. Several nozzles are assembled on one nipple with small volume and wide spray coverage. The droplets size is 1/3-1/2 compared to those produced by a single nozzle with same capacity. An added value to CH full cone nozzle is their wide spray range.

MATERIAL: B1 AISI 303 STAINLESS STEEL THREAD: STANDARD BSP
 B31 AISI 316L STAINLESS STEEL STANDARD NPT
 T1 BRASS



CH

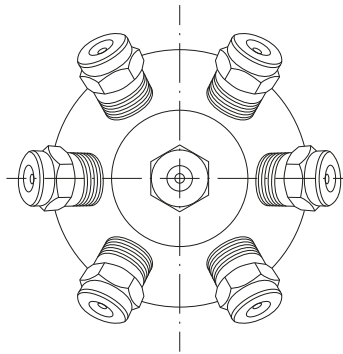

BOTTOM VIEW

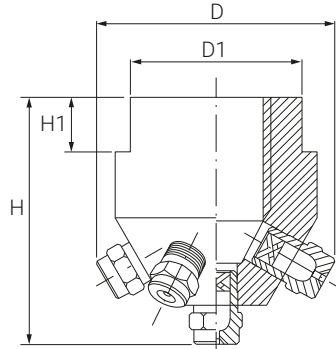

MODEL WITH 7 NOZZLES

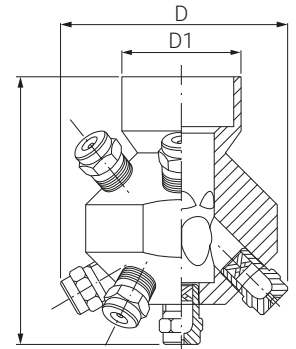

MODEL WITH 13 NOZZLES

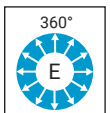
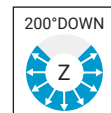

Threaded connections

CODE	Capacity at different pressures l/min bar					Spray coverage deg		RF BSP				Dimensions mm				Number of nozzles
	1,0	2,0	3,0	5,0	10	200	360	3/4"	1"	1-1/2"	2"	D	D1	H	H1	
CHZ 1826 xx	4,77	6,47	8,26	10,7	15,1	•		•				71	40	55	13	7
CHZ 2165 xx	9,53	13,5	16,5	21,3	30,1	•		•				89	46	68	17	
CHZ 2329 xx	19,0	26,9	32,9	42,5	60,1	•			•							
CHZ 2585 xx	33,8	47,8	58,5	75,5	106	•			•							
CHZ 2819 xx	47,3	66,9	81,9	106	150	•			•							
CHZ 3102 xx	59,4	84,0	102	133	188	•				•		128	70	93	20	
CHZ 3131 xx	76,0	107	131	170	240	•				•						
CHZ 3206 xx	119	168	206	267	377	•					•	171	85	122	27	
CHZ 3259 xx	149	211	259	334	473	•					•					
CHZ 3329 xx	190	268	329	425	600	•					•					
CHE 2153 xx	8,83	12,5	15,3	19,8	27,9		•	•				69	39	85	-	13
CHE 2306 xx	17,7	25,0	30,6	39,5	55,9		•	•								
CHE 2611 xx	35,3	49,9	61,1	78,9	111		•		•			86	48	105	-	
CHE 3108 xx	62,7	88,7	108	140	198		•		•							
CHE 3152 xx	87,8	124	152	196	277		•		•							
CHE 3191 xx	110	156	191	246	349		•			•		98	55	120	-	
CHE 3245 xx	141	200	245	316	447		•			•						
CHE 3383 xx	221	313	383	495	700		•				•	129	73	159	-	
CHE 3481 xx	277	392	481	621	878		•				•	169	95	206	-	



SINGLE AXIS HEADS

REACTION DRIVE

The washing action is obtained through water jets coming from a rotating head, where the head motion is obtained purely through reaction force originated by the fluid jets being ejected.

The operating pressure influences the head rotation speed, which must be limited to avoid the water jets being broken into minute droplets and losing part of their impact force.

These devices perform very satisfactorily in a great number of general applications, where the products to be washed away do not originate severe problems and with limited size tanks.

To cope with the large variety of industrial applications we offer heads made out completely of stainless steel, out of PTFE, PVDF or a mix of those materials.

Connections are obtained through female thread or easy to clean clip fix slip-on pipe

MOTOR DRIVE

A further step in performance with one axis heads performance is obtained with a design where a very simple friction motor provides for low speed rotating head.

This design offers a remarkable advantage because of the lower rotation velocity: the jets remain coherent without being broken into droplets by centrifugal force and all of their impact energy can be transferred to the tank surface



UBB

UBB heads are specially designed for applications where chemical attack from strong acids is to be expected, or when contamination to the product being handled is to be excluded, and are therefore entirely made out of PTFE.

Their rotary motion is produced from the reaction forces of their solid stream water jets, which are arranged in such a way that the inner tank surface is thoroughly covered when the head rotor is in motion. The simple design, a two-piece construction, assures for long, maintenance free service. The wide range of capacities and the choice among several spray patterns makes it easy to find the right product to suite a variety of different applications. The codes shown in the capacity table refer to BSP threads.

Our offices can supply coding for products designed with NPT threads.

MATERIAL: E1 PTFE (FDA APPROVED)
 LT 95° C
 LP 4.0 BAR

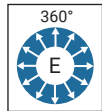
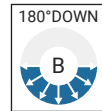
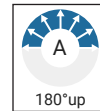

BSP Thread Connection

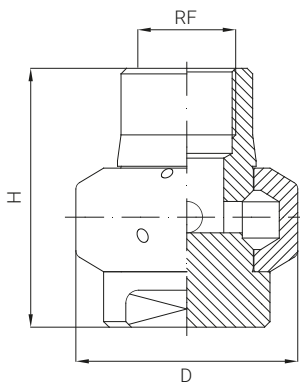

CODE	RF BSP	Capacity at different pressures					Dimensions mm	
		1,5	2,0	2,5	3,0	3,5	H	D
UB B 0003 E1xG	1/2"	21,5	24,7	27,5	30,0	32,3	60	50
UB B 0004 E1xG	3/4"	22,9	26,3	29,3	32,0	34,5	70	60
UB B 0007 E1xG		50,2	57,6	64,1	70,0	75,4		
UB B 0012 E1xG		86,0	98,8	110	120	129		
UB B 0018 E1xG	1"	130	150	167	182	196	75	70
UB B 0020 E1xG		143	165	183	200	215		
UB B 0027 E1xG		197	225	252	275	296		
UB B 0035 E1xG	2"	255	292	325	355	382	110	125
UB B 0039 E1xG		283	325	362	395	425		
UB B 0049 E1xG		355	407	454	495	533		
UB B 0059 E1xG		423	486	541	590	635		
UB B 0069 E1xG	3"	495	568	632	690	743	150	175
UB B 0098 E1xG		706	811	902	985	1061		
UB B 0118 E1xG		846	971	1081	1180	1271		
UB B 0138 E1xG		989	1136	1264	1380	1486		

In order to obtain the complet code of the tank washing head, you need to change the "x" letter, in second to last position, with the corresponding letter concerning the spray coverage, among the ones available.

UBC

UBC series heads are completely made out of stainless steel, with the rotating sphere rolling on two ball bearing rows, to make operation possible in any position. Inner and outer surfaces are carefully machined, deburred, cleaned and polished to a precisely defined roughness grade to avoid contamination from bacterial growth. UBC series heads are available with different connection designs, that is a female thread and a clip-on connection as standard, on request a weld-on or a *tri-clamp connection (with this configuration, the head cannot be ATEX certified)*. The robust and simple design, the high quality construction, long trouble-free service and remarkable efficiency have made them very popular for general purpose applications, in thousands of applications all over the world. The UBC washing head is also available with an NPT connection.



MATERIAL: B31 AISI 316L STAINLESS STEEL
L61 ALLOY C22

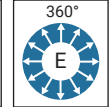
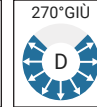
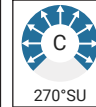
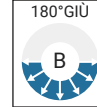

Female BSP Thread

CODE	Capacity at different pressures l/min bar				Spray coverage deg				RF BSP					Dimensions mm	
	2,0	3,0	5,0	7,0	360	270S	270G	180G	3/8"	1/2"	3/4"	1"	1-1/4"	H	D
UBC 2100 B31xG	8,16	10,0	12,9	15,3					55	25
UBC 2300 B31xG	24,5	30,0	38,7	45,8					115	45
UBC 2480 B31xG	39,2	48,0	62,0	73,3					131	65
UBC 2629 B31xG	51,4	63,0	81,3	96,2						
UBC 2899 B31xG	73,5	90,0	116	137						
UBC 2630 B31xG	51,4	63,0	81,3	96,2						
UBC 2900 B31xG	73,5	90,0	116	137						
UBC 3135 B31xG	110	135	174	206						
UBC 3120 B31xG	98,0	120	155	183						
UBC 3215 B31xG	176	215	278	328						
UBC 3300 B31xG	245	300	387	458						

Male BSPT Thread

CODE	Capacity at different pressures l/min bar				Spray coverage deg				RG BSPT					Dimensions mm	
	2,0	3,0	5,0	7,0	360	270S	270G	180G						H	D
UBC M007 B31BEG	5,7	7,0	9,0	10,7	G 1/4" BSP					32,8	14
UBC M023 B31DEB	18,9	23,0	29,4	34,5	R 1/2" BSPT					43,5	21,5

Clip-on connection

Available on request with American pin. Last letter of the code: D insted of C

CODE	Capacity at different pressures l/min bar				Spray coverage deg				Pipe e connection mm	Clip-on Tubo	Standard	Dimensions mm	
	2,0	3,0	5,0	7,0	360	270S	270G	180G				H	D
UBC 2480 B31xC	39,2	48,0	62,0	73,3	22 x 20	3/4"	ASTMA 270	70	25
UBC 2630 B31xC	51,4	63,0	81,3	96,2	29 x 25,3	DN 25	SMS 3008	135	45
UBC 2900 B31xC	73,5	90,0	116	137	29 x 25,3	DN 25	SMS 3008	137	45
UBC 3120 B31xC	98,0	120	154	183	29 x 25,3	DN 25	SMS 3008	135	45
UBC 3135 B31xC	110	135	174	206	29 x 25,3	DN 25	SMS 3008	137	45
UBC 3178 B31xC	145	178	230	272	29 x 25,3	DN 25	SMS 3008	137	44,5
UBC 3300 B31xC	245	300	387	458	44 x 38,4	DN 40	SMS 3008	159	65

Welded connection

CODE	Capacity at different pressures l/min bar				Spray coverage deg				Pipe connection mm	DN	Standard	Dimensions mm	
	2,0	3,0	5,0	7,0	360	270S	270G	180G				H	D
UBC 2200 B31xS	16,3	20,0	25,8	30,6	12,7 x 9,4	DN 10	DIN 11866/C	69	25
UBC 2300 B31xW	24,5	30,0	38,7	45,8	19,05 x 15,75	DN 15	DIN 11866/C	78	25
UBC 2630 B31xW	51,4	63,0	81,3	96,2	25,4 x 22,1	DN 25	DIN 11866/C	250	45
UBC 2900 B31xW	73,5	90,0	116	137	25,4 x 22,1	DN 25	DIN 11866/C	250	45
UBC 3120 B31xS	98,0	120	155	183	25 x 21	DN 25	DIN 11866/C	250	45
UBC 3135 B31xV	110	135	174	206	29 x 26	DN 25	DIN 11866/A	250	45
UBC 3300 B31xS	245	300	387	458	38 x 34	DN 40	DIN 11866/C	250	65

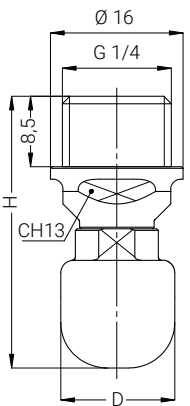
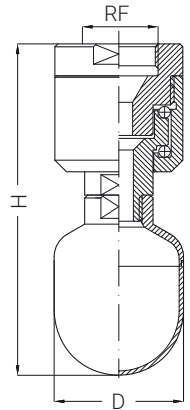

UBC M007 B31BEG

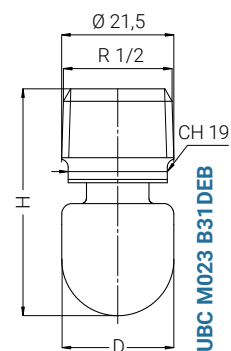

UBC M023 B31DEB

UBD

UBD rotary heads can profit from the special design of their rotary head, which allows for a very even water distribution, assuring optimum surface coverage. They assure therefore very short washing cycles, using lower quantities of water, with a definite advantage in those applications where recycled water is not allowed as a washing medium, and the volumes sent to disposal must be kept to a minimum. UBD heads work using Teflon slide bearings floating at high speed over a thin water film, the only wear part being an easily replaceable Teflon washer. Only a fraction of the liquid energy is then used to power the washing head, while the high speed of the rotating disc produces instantly a cloud of high energy droplets all over the inside surface of the tank. The clever design of this device results in no maintenance at all being necessary. The extremely simple design makes sanitizing quick and easy. Also available with NPT connection.

MATERIAL: BODY, SHAFT AND ROTARY HEAD B31 AISI 316L STAINLESS STEEL
 BEARINGS: E1 PTFE

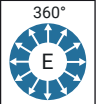
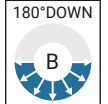
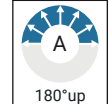

Thread connection

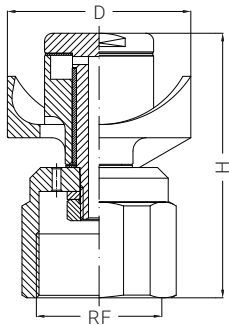

UBD 0140

CODE	Flow rate at different pressure l/min bar					Spray coverage deg			RG BSP		RF BSP		Dimensions mm	
	2,0	3,0	4,0	5,0	7,0	180°S	180°G	360°	1/4"	3/4"	1"	1-1/2"	H	D
UBD 0051 B31AG	41,0	50,0	58,0	64,0	76,0	.				.			55	35
UBD 0051 B31BG	41,0	50,0	58,0	64,0	76,0		.			.			55	38
UBD 0051 B31EG	41,0	50,0	58,0	64,0	76,0			.		.				
UBD 0090 B31AG	73,0	90,0	104	116	137	.				.			75	50
UBD 0090 B31BG	73,0	90,0	104	116	137		.			.				
UBD 0090 B31EG	73,0	90,0	104	116	137			.		.			100	70
UBD 0091 B31AG	73,0	90,0	104	116	137	.				.				
UBD 0091 B31BG	73,0	90,0	104	116	137		.			.				
UBD 0091 B31EG	73,0	90,0	104	116	137			.		.				
UBD 0140 B31AG	114	140	162	181	214	.				.				
UBD 0140 B31BG	114	140	162	181	214		.			.				
UBD 0140 B31EG	114	140	162	181	214			.		.				
UBD 0141 B31AG	114	140	162	181	214	.				.				
UBD 0141 B31BG	114	140	162	181	214		.			.				
UBD 0141 B31EG	114	140	162	181	214			.		.				
UBD 0210 B31AG	171	210	242	271	321	.				.				
UBD 0210 B31BG	171	210	242	271	321		.			.				
UBD 0210 B31EG	171	210	242	271	321			.		.				

Models with 3/4", 1", 1-1/2" connections can be provided also with NPT thread: in this case, H can be slightly different.

Made without the need for bearings, they are the version of the UBD range with a 1/4" BSP male thread. The rotor completely in Teflon reduces friction to a minimum, eliminating any lubrication need. Because of its small size, this head is ideal for the internal washing of small tanks with not too viscous residues. Also available with NPT connection.

MATERIAL: HEAD B31 AISI 316L S.S.
 L61 HASTELLOY C22
 ROTOR E1 PTFE



Thread connection

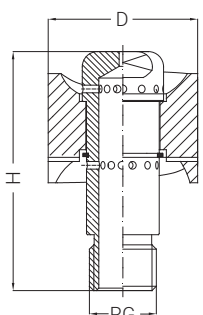

CODE	Flow rate at different pressure l/min bar					Spray coverage deg			RG BSP		RF BSP		Dimensions mm	
	2,0	3,0	4,0	5,0	7,0	180°S	180°G	360°	1/4"	3/4"	1"	1-1/2"	H	D
UBD 0035 B31AG	29,0	35,0	40,0	45,0	53,0	.				.			45	28
UBD 0035 B31BG	29,0	35,0	40,0	45,0	53,0		.			.				
UBD 0035 B31EG	29,0	35,0	40,0	45,0	53,0			.		.				
UBD 0050 B31AG	41,0	50,0	58,0	64,0	76,0	.				.				
UBD 0050 B31BG	41,0	50,0	58,0	64,0	76,0		.			.				
UBD 0050 B31EG	41,0	50,0	58,0	64,0	76,0			.		.				

UBD A

UBD A rotary heads are a simple but very efficient device for the inside cleaning of tanks. The rotary disk is rotated through the action of the cleaning fluid and produces a very dense spray which reaches all parts of the inside surface, it is the only mobile part of the unit and requires no servicing at all. No lubrication is required, and therefore no risk exists of contaminating your product with oil or grease. Ideally suited for aggressive environments, it operates efficiently with all detergents and chemical solutions, in both closed and open tanks because available with 360 or 180 degrees spray patterns. UBD A models find their application in pharmaceutical, chemical and food industries.

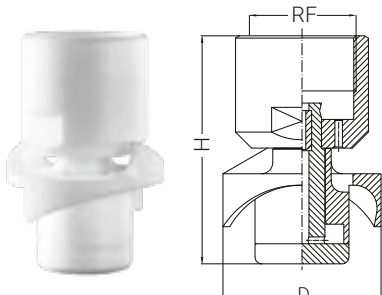

UBD A140

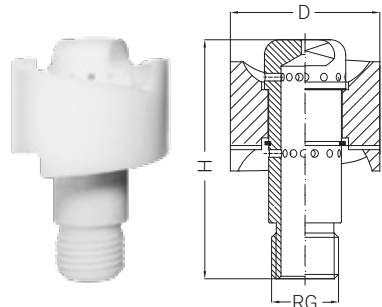

UBD A035

MATERIAL: E1 PTFE PURE (FDA APPROVED)
 E11 PTFE + 15% GRAPHITE
 D9 PEEK (FDA CONFORME)
 LT: 95° C

Thread connection

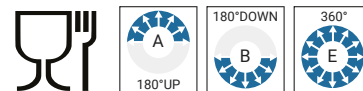

CODE	Flow rate at different pressure l/min bar					Copertura gradi			RM BSP		RF BSP		Dimensions mm	
	2,0	3,0	4,0	5,0	6,0	360	180S	180G	1/4"	3/4"	1"	1-1/2"	H	D
UBD A035xxEG*	28,6	35,0	40,5	45,2	49,5	47	30
UBD A051 xxEG	41,2	50,0	57,4	63,9	69,7	55	40
UBD A090 xxEG	73,5	90,0	104	116	127	49	40
UBD A090 xxAG	73,5	90,0	104	116	127	49	40
UBD A090 xxBG	73,5	90,0	104	116	127	49	40
UBD A140 xxEG	114	140	162	180	198	75	50
UBD A140 xxAG	114	140	162	180	198	75	50
UBD A140 xxBG	114	140	162	180	198	75	50
UBD A210 xxEG	171	210	243	271	296	100	70
UBD A210 xxAG	171	210	243	271	296	100	70
UBD A210 xxBG	171	210	243	271	296	100	70

*UBD A035xxEG has 1/4" male thread.

UBD S

Reaction drive mono-axial head UBD S035 B31EG is totally realized in AISI 316L stainless steel. Moreover, no lubrication is needed, therefore there is no risk of contamination with oils: this product is suitable in applications in food, pharmaceutical and chemical industries. It has a low capacity and low angular velocity, so it is perfect for washing small and medium size tanks that require longer washing cycles. The easy and strong design, and high quality structure assure a long service and a high efficiency.

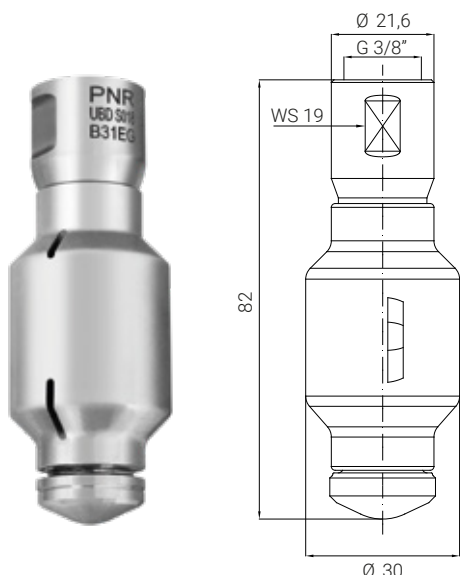

MATERIAL: B31 AISI 316L STAINLESS STEEL
 CONNECTION: 3/8" BSP FEMALE
 CLIP-ON
 NPT
 LT: 85°C (limit imposed by ATEX certification)
 LP: 10 bar (limit imposed by ATEX certification)



CODE	Capacity at different pressures l/min bar						
	2,0	3,0	5,0	7,0	10	12	15
UBD S013 B31E...CA	11	13	17	20	24	26	29
UBD S018 B31E...CA	15	18	23,3	27,5	33	36	40,2
UBD S040 B31E...CA	33	40	51,6	61	73	80	89,4

We recommend using with a filter of at least 100 mesh.
 The purpose is referred to the threaded model.
 Read more about MOCA certification on page 32.

UBX

UBX is a very compact product whose design provides for a specially accurate cleaning of the upper area of the tank around the inlet pipe, which is accomplished by a larger rotating head and straight jets with a well studied and appropriate orientation. Because of the low flow values, the simple design and the high quality surface finish UBX tankwashers are preferred in such application as washing small volume tanks in pharmaceutical processes.

The rotation is obtained by liquid reaction forces, while the head rotates over a thin liquid film which is self-cleaning. Connection can be threaded or with standard PNR clip for easy disassembly and cleaning.

MATERIALI: BODY B31 AISI 316L STAINLESS STEEL
 ROTOR E1 PTFE
 E13 PTFE + CARBON
 D9 PEEK (ON REQUEST)

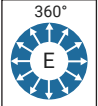
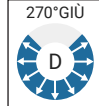
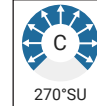

Thread connection

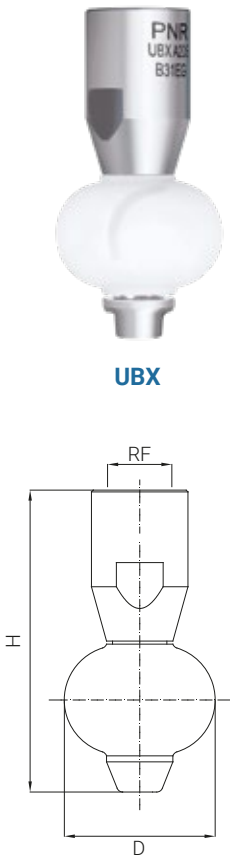

CODE	Capacity at different pressures					Spray coverage deg			RF BSP				Dimensions mm		
	2,0	3,0	4,0	5,0	6,0	360	270S	270G	1/4"	3/8"	1/2"	3/4"	H	D	
UBX A10S B31EG	8,20	10,0	11,6	12,9	14,1	.			.				50	25	
UBX A10A B31DG	8,20	10,0	11,6	12,9	14,1		.		.						
UBX A15S B31EG	12,2	15,0	17,3	19,4	21,2	.			.						
UBX A20C B31CG	16,3	20,0	23,1	25,8	28,3		.		.						
UBX A20S B31EG	16,3	20,0	23,1	25,8	28,3	.			.						
UBX A20S B31CG	16,3	20,0	23,1	25,8	28,3		.		.						
UBX A20S B31 DG	16,3	20,0	23,1	25,8	28,3			.	.						
UBX A30A B31EG	24,5	30,0	34,6	38,7	42,4	.			.			60	30		
UBX A30A B31DG	24,5	30,0	34,6	38,7	42,4		.		.						
UBX A30S B31EG	24,5	30,0	34,6	38,7	42,4	.			.						
UBX A30S B31CG	24,5	30,0	34,6	38,7	42,4		.		.						
UBX A30S B31DG	24,5	30,0	34,6	38,7	42,4			.	.						
UBX A40A B31EG	32,7	40,0	46,2	51,6	56,6	.			.			75	40		
UBX A40S B31EG	32,7	40,0	46,2	51,6	56,6	.			.						
UBX A40S B31CG	32,7	40,0	46,2	51,6	56,6		.		.						
UBX A40S B31DG	32,7	40,0	46,2	51,6	56,6			.	.						
UBX A50S B31EG	40,8	50,0	57,7	64,5	70,7	.			.			100	50		
UBX A70A B31EG	57,1	70,0	80,8	90,4	99,0	.			.						
UBX A70S B31EG	57,1	70,0	80,8	90,4	99,0	.			.						
UBX A70A B31CG	57,1	70,0	80,8	90,4	99,0		.		.						
UBX A70A B31DG	57,1	70,0	80,8	90,4	99,0			.	.						



PNR Italia is introducing on the market its classic products made of **MDT material** (*magnetically detectable thermoplastics*) and specifically **PPh** (*polypropylene homopolymer*).
 MDT compounds are created to be detected by any type of detector, even when present in very small parts, making them suitable for metal replacement. MDT compounds are traceable by all metal detectors on the market (both fixed magnet and balanced coil ones), unlike compounds loaded with ferromagnetic powders. Furthermore, the MDT compounds do not use steel fibers or metal powders, and they do not contain carbon, graphite or carbon black fibers. Thanks to these characteristics, components manufactured with MDT do not release, in operation, powders or particles that are difficult to confine and therefore capable of dispersing in the working atmosphere and remotely contaminating the process or finished products.
 MDT products are suitable for contact with food, and are produced in dark blue color in order to be better identified in any circumstance.

UBF SMALL DIMENSION WASHING HEADS

UBF range heads have been designed as small dimensions devices to be operated through small dimension openings and perform such processes as the inside cleaning of any other container where standard washing heads cannot be used. Typically used for cleaning beer kegs, containers for soft drinks or small bore pipes. Also available with NPT connection.

MATERIAL: B31 AISI 316L STAINLESS STEEL + BEARINGS PTFE
 L61 ALLOY C22
 LP: 10 bar (limit imposed by ATEX certification)

EXCLUSIVE TRUMPET ORIFICE

The new trumpet design of the side orifices allows to obtain a more efficient fan shaped jet, with a well defined spray angle, improving considerably the washing action.

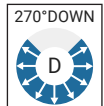
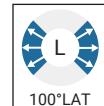
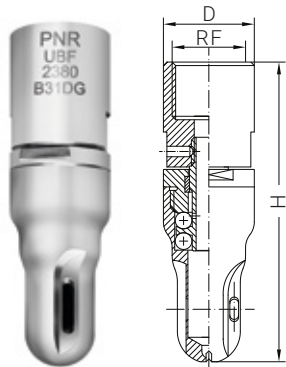

CODE	RF BSP	Capacity at different pressures					Spray coverage deg		Dimensions mm	
		2,0	3,0	5,0	10	12	100L	270G	H	D
UBF 2270 B31 LG	1/2"	20,0	27,0	36,4	51,5	56,4	.	.	85	26
UBF 2270 B31DG		22,0	27,0	36,4	51,5	56,4	.	.		
UBF 2380 B31DG		31,0	38,0	49,2	69,3	76,0	.	.		

UBF A

Designed for cleaning processes in small bore piping or small size containers and available in a range of different plastic materials and special alloys, as well as with several spray angles. Also available with NPT connection.

MATERIAL: D82 PVDF (MOLDED)
 B31 AISI 316L STAINLESS STEEL + BEARINGS PTFE
 E1 PTFE (FDA APPROVED)
 L61 HASTELLOY C22

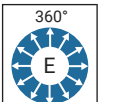
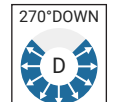
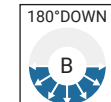
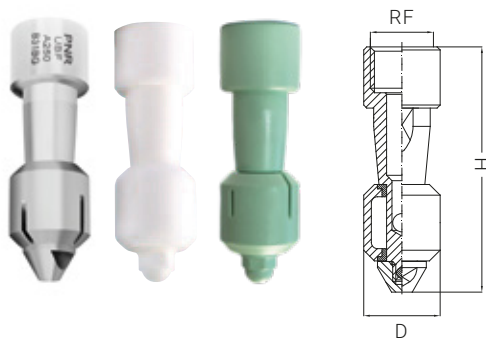

CODE	RF BSP	Capacity at diff. pressures			Spray coverage deg			Dimensions mm	
		2,0	3,0	4,0	180G	270G	360	H	D
UBF A250 xxBG	1/2"	20,0	25,0	28,8	.	.	.	80	25
UBF A250 xxDG		20,0	25,0	28,8	.	.	.		
UBF A250 xxEG		20,0	25,0	28,8	.	.	.		

UBF S

Designed for cleaning processes in very small bore piping or containers, down to 13 mm diameter. The device is available in different materials as well as spray angles, and with NPT connection

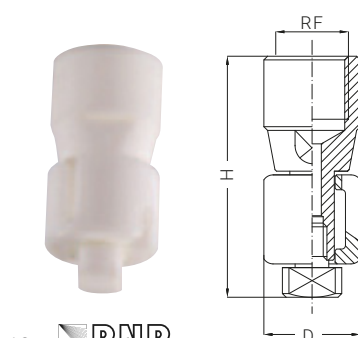

MATERIAL: B31 AISI 316L STAINLESS STEEL
 L61 ALLOY C22
 E1 PTFE (FDA APPROVED)

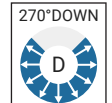

CODE	RF BSP	Capacity at diff. pressures			Spray coverage deg	Dimensions mm	
		2,0	3,0	4,0	270G	H	D
UBF S055 xxDG	1/8"	4,50	5,50	6,40	.	32	13

UBA

UBA series heads operate producing water jets out of a spray head rotating around a vertical axis, but feature a sophisticated design where the head is put in slow motion by a simple friction transmission. As the motor produces a low rotation velocity, the jets can work with their maximum efficiency since not being broken into droplets: this makes it possible to obtain a higher impact force onto the tank wall. The head design can include one jet directed upwards which is meant to clean the tank roof area around the feed pipe, a difficult area in many instances, realizing then a true 360° spray pattern.

Superior cleaning power, faster cleaning cycles and lower volumes of cleaning solution required. UBA washing heads are available in two sizes, and three different jet patterns, as shown below. Rotation speed varies, depending upon feed pressures, between 5 and 12 rpm. Thread connection are available both in BSP standard (last letter of the code: G) and NPT standard (last letter of the code: N).

MATERIAL:	BODY, SPHERE	B31	AISI 316L STAINLESS STEEL
		L61	ALLOY C22
		E1	PTFE (ONLY MODEL 3150)
	BUSHINGS	E1	PTFE
	MOTOR RING	E1	PTFE

only for:
AISI 316L
Alloy C22

360°
E

270°DOWN
D

180°DOWN
B

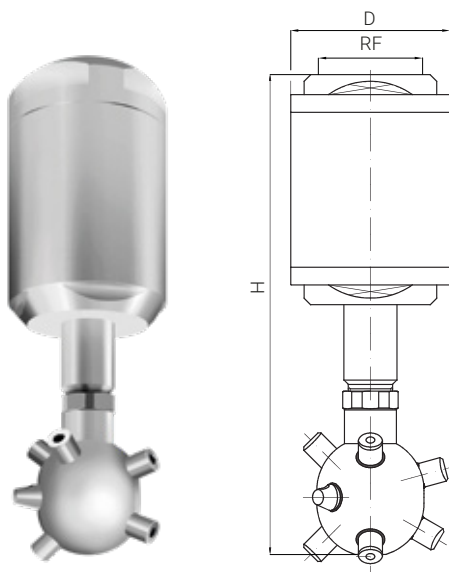

UBA 3150

CODE	RF BSP	Capacity at different pressures				l/min bar	Spray coverage deg			Dimensions mm	
		3,0	5,0	7,0	10		180G	270G	360	H	D
UBA 2500 B31BG	3/4"	50,0	64,5	76,3	91,3	.			166	50	
UBA 2500 B31DG		50,0	64,5	76,3	91,3		.				
UBA 2500 B31EG		50,0	64,5	76,3	91,3			.			
UBA 3150 B31EG	1-1/2"	110	142	168	200			.	216	71	

UBA tank washing head is designed to accommodate, on its head, a wide range of different nozzles, both as number and type (flat fan, straight, etc.). Every personalization involves some difference in the performance compared to the ones in the table: they will be provided case by case.

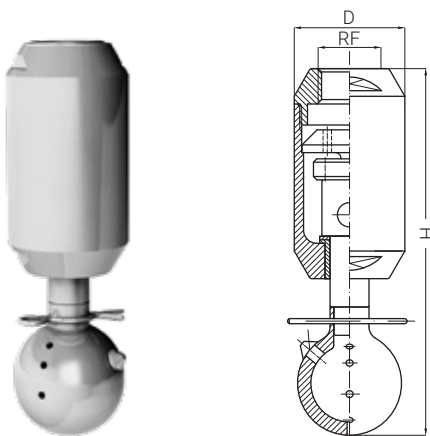

UBA 2500



TWIN AXIS HEADS

TWIN AXIS HEADS

The most sophisticated tank washing equipment, where high impact fluid jets slowly move with a combined rotation around one vertical and one horizontal axis. The motive mechanism assures the jet to hit always different paths at each turn, so that each single point of the inner tank surface is surely cleaned.

TURBINE DRIVE

Sophisticated products offering modern design, excellent performance and high surface quality, mainly suitable for the chemical and pharmaceutical industry as they fully satisfy their demand for safe and reliable operation as well as perfect cleaning and sanitation.



UBT

The UBT series tank wash heads are very sophisticated devices, designed with a robust structure and constructed with the latest technology to allow for high performance and providing excellent disinfection after each wash cycle. These characteristics are ideal for the automatic cleaning of industrial tanks and vessels. The nozzle movement is operated through an internal epicyclical gear reducer which enables to drive the jet paths according to a preset grid over the tank surface, providing a perfect cleaning of every single area inside the tank. Each side hub is equipped with two nozzles.

Depending on the application, two different types of nozzle can be used:

- Short nozzle: length 20 mm (Model C)
- Long nozzle: length 50 mm (Model L)

Each side hub is equipped with two nozzles whose orifice diameter determines the total water flow rate.

OPERATING CONDITIONS:	LT	85°C (limit imposed by ATEX certification)	MATERIAL:	METAL PARTS	AISI 316L STAINLESS STEEL
	LP	10 BAR		SEALS	CPTFE TEFLON + GRAFITE
			OTHER MINOR PARTS	PEEK	

CONNECTION: FEMALE BSPP THREAD (ISO 228)
NPT



ATEX version available only for the variant coded with final R (ex: UBT Sxxx B31xxR)

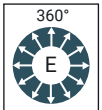

MODEL C "SHORT"

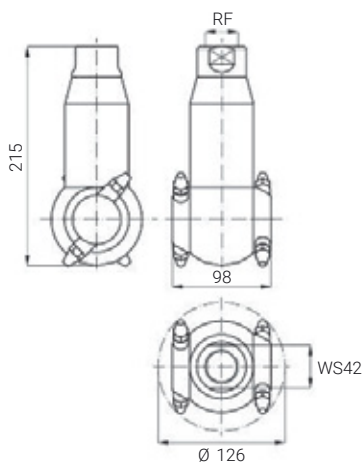

CODE	Ø mm	RF BSPP	Capacity at different pressures							l/min bar	Weight Kg
			4,0	5,0	6,0	7,0	8,0	9,0	10		
UBT S445 B31CG	6,0	1"	88	92	100	108	115	121	130	3,6	
UBT S445 B31LG			88	92	100	108	115	121	130		
UBT S460 B31CG			115	120	130	138	150	158	162		
UBT S460 B31LG			115	120	130	138	150	158	162		

To order the required product, please note that:
a) second to last letter "C" indicates the Model C (short nozzle);
b) second to last letter "L" indicates the Model L (long nozzle).
Ø is the nozzle diameter.



MODEL L "LONG"

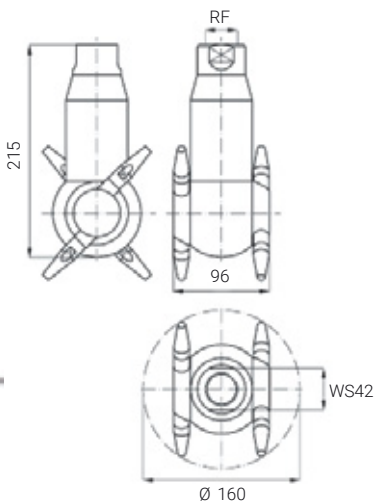

In order to avoid problems with the device (such as breaking), we suggest to you filtered water. PNR Italia suggests a filter with at least 60 mesh, such as VEM 0100 V1 (see next page for further information).



WETTING RADIUS UBT S445

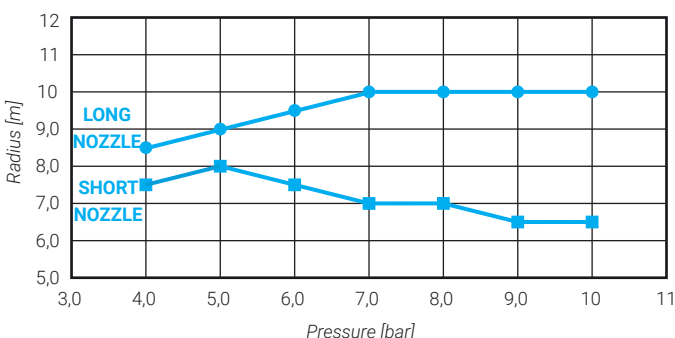

WETTING RADIUS UBT S460

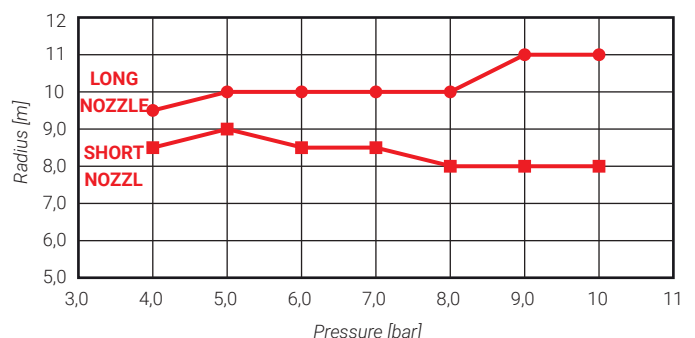

VEM

VEM filters have been designed for high efficiency and ease of maintenance under hard conditions. The bowl houses large size cartridges, to extend periods of operation and reduce maintenance time, and has a thread connection to the body for quick removal without the aid of tools. Finally, a plug at the bottom of the bowl allows for fitting a ball valve to bleed the filter.

MATERIAL:	BODY	V1	ALUMINIUM CASTING
	BOWL	V1	ALUMINIUM CASTING
	CARTRIDGE	B2	AISI 304 STAINLESS STEEL
	CAP	A8	ZINC-COATED STEEL
	SEAL	E0	EPDM

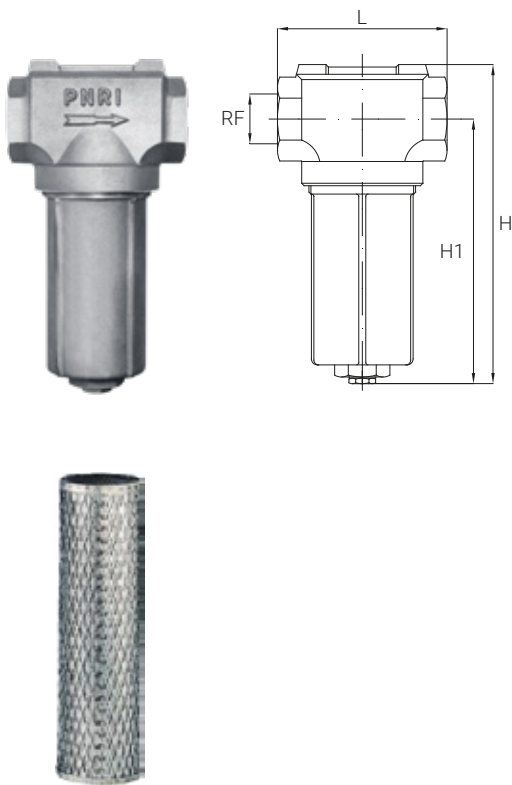

CODE	RF inch BSP	H mm	H1 mm	L mm	LP bar	Q l/min	Cartridge	M mesh	W kg
VEM 0050 V1 VEM 0051 V1	1/2"	213	168	105	40	70	XVE M075 B2 XVE M076 B2	60 80	0,9
VEM 0075 V1 VEM 0076 V1	3/4"	213	168	105	40	95	XVE M075 B2 XVE M076 B2	60 80	
VEM 0100 V1 VEM 0101 V1 VEM 0102 V1	1"	213	168	105	40	140	XVE M075 B2 XVE M076 B2 XVE M077 B2	60 80 100	
VEM 0125 V1 VEM 0126 V1	1-1/4"	278	233	140	30	280	XVE M150 B2 XVE M151 B2	60 80	1,6
VEM 0150 V1 VEM 0151 V1	1-1/2"	278	233	140	30	315	XVE M150 B2 XVE M151 B2	60 80	
VEM 0200 V1 VEM 0201 V1 VEM 0202 V1	2"	401	327	200	10	750	XVE M300 B2 XVE M301 B2 XVE M302 B2	30 60 80	5,6
VEM 0250 V1 VEM 0251 V1 VEM 0252 V1	2-1/2"	401	327	200	10	810	XVE M300 B2 XVE M301 B2 XVE M302 B2	30 60 80	
VEM 0300 V1 VEM 0301 V1 VEM 0302 V1	3"	401	327	200	10	1050	XVE M300 B2 XVE M301 B2 XVE M302 B2	30 60 80	

FILTER CARTRIDGE

In the table, you find the code of the cartridges available for every filter. The column "M" near the cartridge code show the value of filtration, in number of mesh.

MESH number	Free passage mm
30	0,60
60	0,25
80	0,18
100	0,15

UBT ACCESSORIES

Head-carrying carts are the most convenient solution for fast washing of tanks raised from the ground with an opening in the bottom. The base with wheels and the pantograph raising mechanism allow an easy positioning of the system at the base of the tank and a quick insertion of the washing head inside, with the aid of a manual crank handle. The carts are designed to be equipped with a UBT series washing head, ideal for a complete medium pressure cleaning in every corner of the tank, thanks to the automatic bi-axial rotation mechanism.

MATERIAL: STRUCTURE AISI 304L STAINLESS STEEL CONNECTION: 1" BSPT (MALE)
 WHEELS PTFE

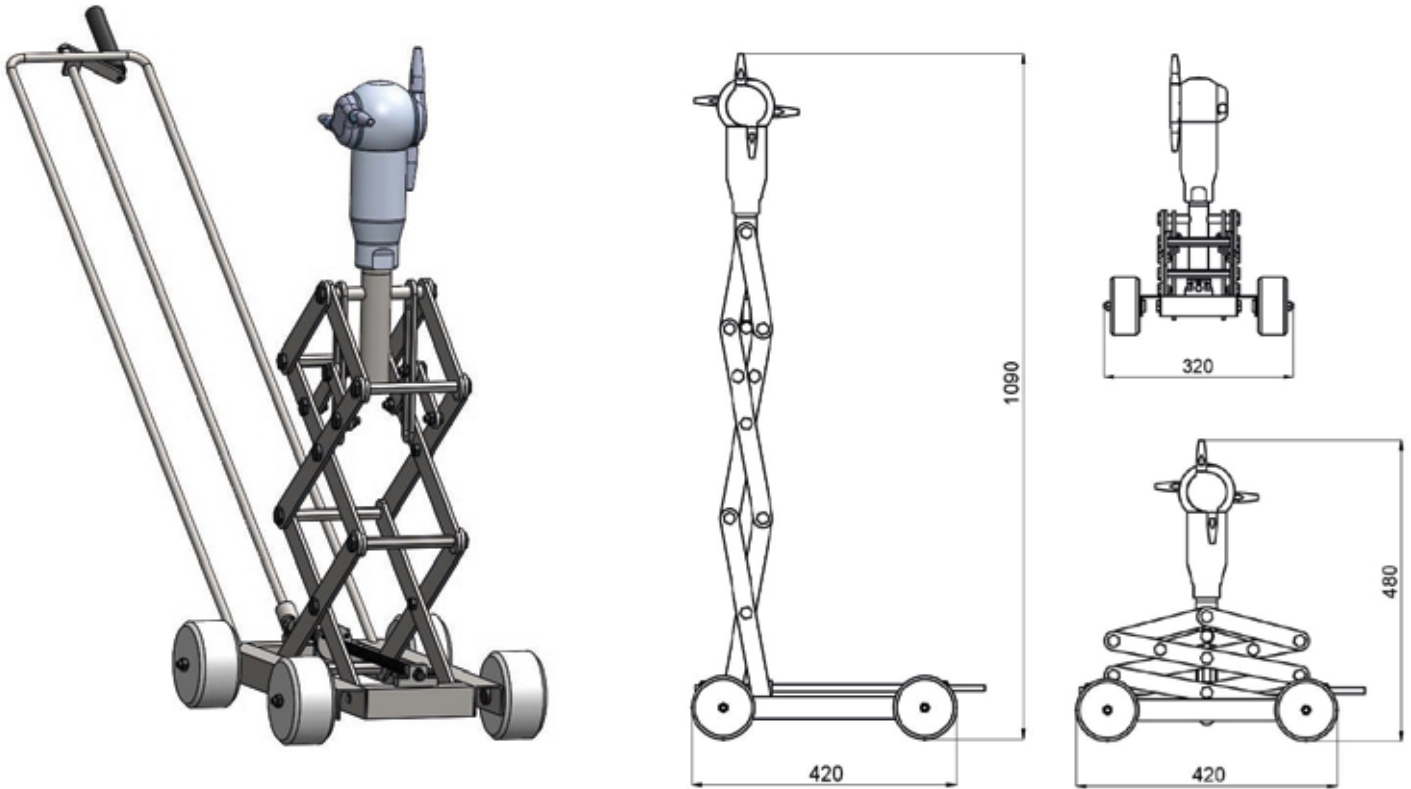

The dimensions are explanatory, please contact us for further information.

ADVANTAGES

- High portability
- Stability and resistance
- Easy to install and to use
- 360° cleaning of the tank

TYPICAL APPLICATIONS

- Food and beverage industry
- Chemical and petrochemical industry
- Pharmaceutical industry
- Environmental industry



UMV

The UMV series washgun has been designed primarily to avoid hot water waste, while assuring very comfortable operation conditions. Its thick rubber casing not only effectively protects the operator's hand from the discomfort of hot water but also assures an excellent protection in case the washgun is dropped or falls to the ground since it avoids any damage to the tiles or the equipment. The careful design, mainly used for the food industry, also includes a grease and detergent resistant quality rubber, plus a blue colour has been chosen as a visual aid to be seen clearly against a white or clear foreground. The trigger is lined too, and can be held in the open position by means of a lock-ring. The spray pattern can be adjusted continuously between a closed straight jet to a wide angle spray, so that the proper spray pattern can be chosen for each individual job.

MATERIAL:

BODY	T2 BRASS CASTING, CHROME PLATED
	B31 AISI 316L STAINLESS STEEL
LINING	E0 EPDM
STEAM	B3 AISI 316 STAINLESS STEEL
TRIGGER	B3 AISI 316 STAINLESS STEEL, RUBBER LINED

PERFORMANCE:

Q	21 LPM @ 3 BAR UMV 2210
	61 LPM @ 3 BAR UMV 2211

TECHNICAL DATA:

HOSE SHANK	13 MM
WEIGHT	0.9 KG
MAX TEMPERATURE	95° C
MAX PRESSURE	24 BAR

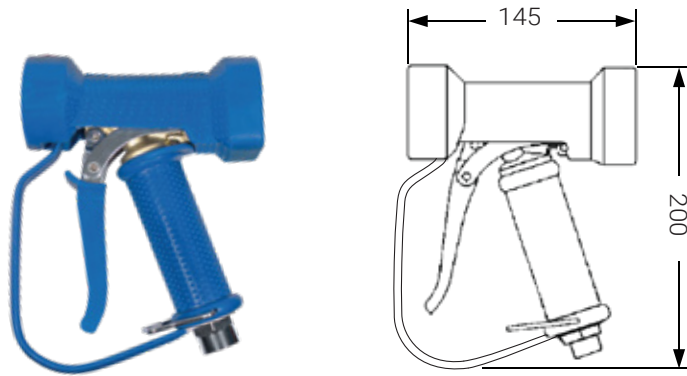

UMV 2210 xx

The versatility of this washgun is enhanced from the additional model UMV 2211 xx, which can be fitted with nozzles or different lances through its 1/2" male thread. The three different lance models shown are easily fitted to the gun body with a 1/2" male nipple and offer the following choices of operation:

- Foaming machines and equipment prior to washing operations. The foam lance comes with a quick connect female coupling, and a matching coupling must be fitted at the gun outlet.
- General purpose 1/4" female thread outlet, 1/4" male thread inlet. Available both with heat protection sleeve, or zincplated steel. The general purpose lance needs a connection nipple 1/4" fem to 1/2" female to be fitted on the gun.

COMPLETE GUNS CODE

UMV 2210 xx	Standard, adjustable jet
UMV 220A xx	With foam lance
UMV 220B xx	With 1/4" female outlet, bare lance
UMV 220C xx	With 1/4" female outlet, heat protected lance

SINGLE COMPONENTS CODE

UMV 2211 xx	With 1/2" male quick thread, without lance
XUM V001 B2	Foam lance
XUM V002 B1	Quick connect coupling for foam lance, 1/2" F
XUM V003 B2	Universal lance, 1/4" F out, heat protection
XUM V004 B2	Universal lance, 1/4" F out, zinc-plated steel
XUM V005 xx	Nipple, 1/4" F x 1/2" F

MATERIAL:

UMV 2210, UMV 2211, UMV 220A, UMV 220B, UMV 220C

B31	AISI 316L STAINLESS STEEL
T2	CHROME-PLATED BRASS

XUM V005

B31	AISI 316L STAINLESS STEEL
T8	NICHEL-PLATED BRASS

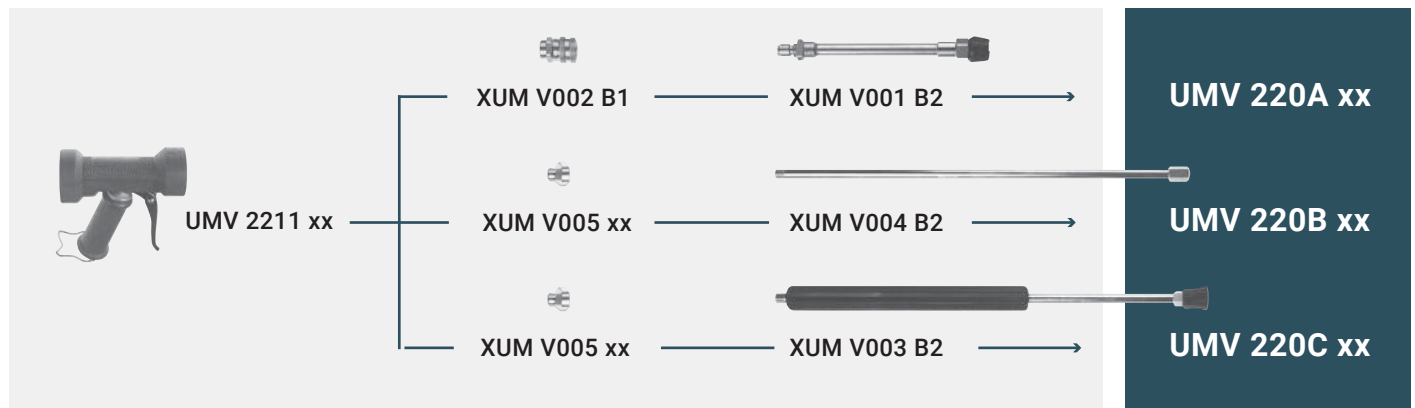

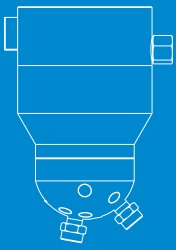

HIGH-PRESSURE HEADS

Thanks to the high impact force of the jets, the high-pressure spray balls use on average less liquid for cleaning than the lower pressures tank washing heads, with substantial long-term savings.

The advantages of using high-pressure washing heads are environmental – thanks to reduced water consumption – and, consequently, economic. The disposal of spent cleaning liquids represents an expensive activity in company budgets. The high-pressure washing heads allow a substantial reduction of this asset, thanks to the reduced water consumption. On the other hand, high-pressure cleaning devices require greater energy expenditure for their correct operation and, therefore, highly performing systems.

The wetting radius of these devices is generally smaller than the medium and low-pressure tank washing heads, settling at around 3m at the most. After this distance, the impact force of the jets decreases drastically. The main applications of high-pressure washing heads are cleaning small-medium size tanks and open or closed containers of limited size characterized by persistent dirt.



REDUCED WATER CONSUMPTION

Thanks to the high impact force of the jets, the high-pressure spray balls use on average less liquid for cleaning than the lower pressures tank washing heads.

APPLICATIONS

The main applications of high-pressure washing devices are cleaning small-medium size tanks and open or closed containers of limited size characterized by persistent dirt.

ECONOMIC SAVING

The disposal of spent cleaning liquids represents an expensive activity in company budgets. The high-pressure washing heads allow a substantial reduction of this asset, thanks to the reduced water consumption.

UBQ

The UBQ washing head is a high-pressure cleaning device for small and medium-sized car parts, bins, and cans. Technologically advanced and sophisticated but at the same time robust, the UBQ washing head is reliable in various applications that require high-pressure washing of persistent residues.

An hydraulic engine keeps the rotating part of the spray ball in motion. Thanks to its design, the device does not require oils or greases for lubrication.

The main innovation of the UBQ head lies in its rotating head. Depending on the application and cleaning needs, the position of the nozzles can vary in different configurations for a total of 6 different angles. 12 enclosures can accommodate a minimum of 2 up to a maximum of 4 F nozzles simultaneously. The flat jet nozzles F are designed explicitly for high-pressure washing. Their internal geometry ensures uniform jet distribution and highly effective cleaning action.

The head is available in the *axial configuration* – with an integrated filter – or *tangential*. Made of AISI 303 stainless steel, the UBQ washing head has a flow rate ranging from 15 to 30 liters per minute to a maximum of 150 bar.

MATERIALS: AISI 303 S.S.

CONNECTIONS: 1/8" BSPP

WATER INLET AXIAL VERSION: 1/2" G

WATER INLET TANGENTIAL VERSION: 3/8" G

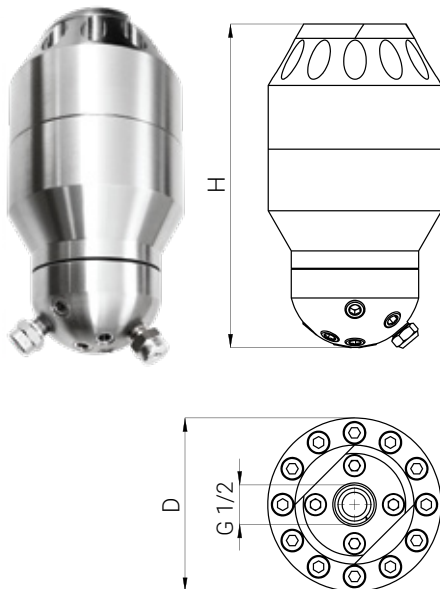
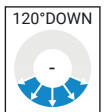

Axial configuration

CODE	Liters per minute [lpm]	Inlet nozzle dimensions [mm]	Water inlet configuration and dimension	Number of nozzles
UBQ A215 B1	15	/	1/2"G	2
UBQ A315 B1	15	/	1/2"G	3
UBQ A415 B1	15	/	1/2"G	4
UBQ A220 B1	20	/	1/2"G	2
UBQ A320 B1	20	/	1/2"G	3
UBQ A420 B1	20	/	1/2"G	4
UBQ A225 B1	25	/	1/2"G	2
UBQ A325 B1	25	/	1/2"G	3
UBQ A425 B1	25	/	1/2"G	4
UBQ A230 B1	30	/	1/2"G	2
UBQ A330 B1	30	/	1/2"G	3
UBQ A430 B1	30	/	1/2"G	4

Tangential configuration

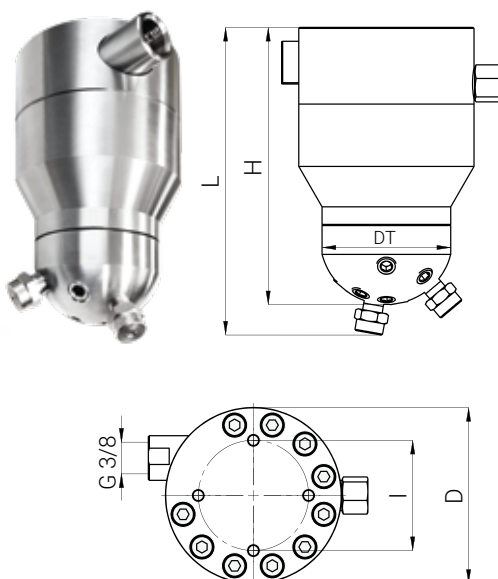

CODE	Liters per minute [lpm]	Inlet nozzle dimensions [mm]	Water inlet configuration and dimension	Number of nozzles
UBQ R215 B1	15	2	3/8"G	2
UBQ R315 B1	15	2	3/8"G	3
UBQ R415 B1	15	2	3/8"G	4
UBQ R220 B1	20	2.5	3/8"G	2
UBQ R320 B1	20	2.5	3/8"G	3
UBQ R420 B1	20	2.5	3/8"G	4
UBQ R225 B1	25	2.5	3/8"G	2
UBQ R325 B1	25	2.5	3/8"G	3
UBQ R425 B1	25	2.5	3/8"G	4
UBQ R230 B1	30	3	3/8"G	2
UBQ R330 B1	30	3	3/8"G	3
UBQ R430 B1	30	3	3/8"G	4

UBR

The washing heads of the UBR series have been designed to wash small containers with an effective high-pressure jet. This product is driven by an external electric or pneumatic motor, allowing only the tube with the rotating head to be introduced into the container to be washed. This configuration ensures high reliability, and the limited dimensions allow for easy transport.

The highest quality materials, high precision mechanical machining, and the choice of motors produced by selected suppliers make these devices ideal in many applications.

These washing heads can be introduced into the tanks with three different solutions:

- *conical caps* for temporary use on openings of various diameters;
- *tri-clamp or swivel joints* for removable mounting;
- *connections with flange* for stationary mounting.

MATERIAL BODY AISI 316 STAINLESS STEEL COVERAGE 360°
SEALS EPDM LT: 150°C

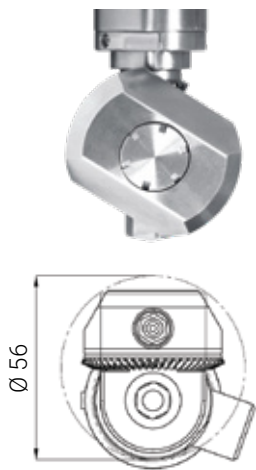
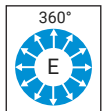

PNR NOZZLES CODE*	FLOW RATE [l/min] at 10 bar	FLOW RATE [l/min] at 15 bar	FLOW RATE [l/min] at 20 bar	FLOW RATE [l/min] at 35 bar	FLOW RATE [l/min] at 50 bar	FLOW RATE [l/min] at 100 bar	FLOW RATE [l/min] at 150 bar	FLOW RATE VARIANT
XUB RN01 C2x	4,34	5,32	6,14	8,12	9,7	13,72	13,72	008
XUB RN02 C2x	5,89	7,21	8,32	11,02	13,16	18,6	18,6	011
XUB RN03 C2x	8,73	10,7	12,34	16,34	19,52	27,6	27,6	016
XUB RN04 C2x	11,45	14,02	16,18	21,42	25,6	36,2	36,2	021
XUB RN05 C2x	14,5	17,8	20,6	27,2	32,6	46	46	027
XUB RN06 C2x	17,7	21,7	25	33,1	39,6	56	56	033
XUB RN07 C2x	21,6	26,5	30,4	40,4	48,2	-	-	040
XUB RN08 C2x	28,8	35,2	40,8	53,8	-	-	-	054

* The final letter x indicates the possibility to choose between 3 types of spray angles:

A → 0°

B → 15°

C → 25°



ELECTRIC MOTOR

PNEUMATIC MOTOR

MOTORIZATIONS	ELECTRIC AND PNEUMATIC
PIPE LENGTH * [L] AND WEIGHT [KG] ELECTRIC VERSION	500 mm > 7.3 Kg 700 mm > 8.9 Kg 1000 mm > 10.5 Kg 1500 mm > 12.1 Kg 2000 mm > 16.9 Kg
PIPE LENGTH * [L] AND WEIGHT [KG] PNEUMATIC VERSION	500 mm > 5.2 Kg 700 mm > 6.8 Kg 1000 mm > 8.4 Kg 1500 mm > 10 Kg 2000 mm > 14.8 Kg
WORKING PRESSURE	from 35 to 150 bar
FLOW RATE	from 8 to 54 l/min @ 35 bar from 17 to 56 l/min @ 150 bar
OPERATING TEMPERATURE	over 150°C
NOZZLES	number 2
WATER CONNECTION	3/8" BSP
MINIMUM OPENING FOR INSTALLATION	Ø > 56 mm

* Possibility of requesting the tube length from a minimum of 500mm

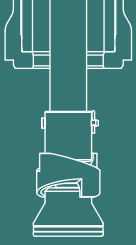

SPECIAL PRODUCTS

In addition to the traditional heads, which fixed position to the surface to wash, PNR offers a range of products with a mobile position for the cover. The mobility of the washing head for this category can be determined by the reaction force of the washing fluid itself (for example, the UC) or by the energy supplied by an actuator, be it hydraulic or pneumatic (UK).

The washing heads defined as exceptional executions divided into two categories:

RETRACTABLE HEADS MOVED BY AN ACTUATOR

Used:

- when a fixed element in the tank can hinder the production process;
- when the process fluid does not come into contact with the washing fluid;
- when a fixed head position inside the tank does not guarantee washing uniformity over the entire surface.

HEADS MOVED BY THE FORCE OF REACTION

of the same washing fluid, mainly used for washing pipes.



UKD / UKR

Our new UK tank washer is a revolution in retractor design, as it offers at the same time greater efficiency, extreme flexibility and an easier operation capability.

We put aside the bulky stainless-steel construction and operate our washing head via a pneumatic drive or CNC. Hence the following advantages:

- the total impact of the water jet is concentrated on the circumference of one or two hollow cone sprays, moving into the tank instead of being inefficiently dispersed over the entire internal surface;
- the alternating movement of the washer covers the total inner surface of the tank and allows what was previously impossible, such as cleaning the opposite sides of an internal mixing blade;
- having control of cylinder movement, we can program short cycles concentrated over difficult points as many times as necessary; our standard double hollow cone head has a capacity of 100 lpm at 3 bar, but customized designs can be studied, according to customer requirements.

Of course, you can use our new UK retractor as a standard one, which is installing on it a rotating head from our UBD series.

MATERIAL: AISI 316L S.S., EPDM, TEFLON/PEEK

CONNECTIONS: HEAD STRUCTURE FIXED WITH TRI-CLAMP CONNECTION
SUPPORT STRUCTURE WELDED TO THE TANK

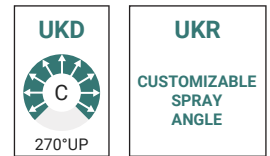

STROKE	A	B	C	D	E	F	Q	D1*	D2	D3	D4	WS	RG1	RG2	RG3
100 ÷ 500 STEP 50 mm	260	108	~60	~40	~120	50	75	65	42	~90	77,5 DIN 32676-C 2" 1/2 T.C	30	1/2"	3/8"	3/8"

* This must be the hole of the tank. RG1: fluid inlet connection. RG2, RG3: air inlet connection to extend / retract

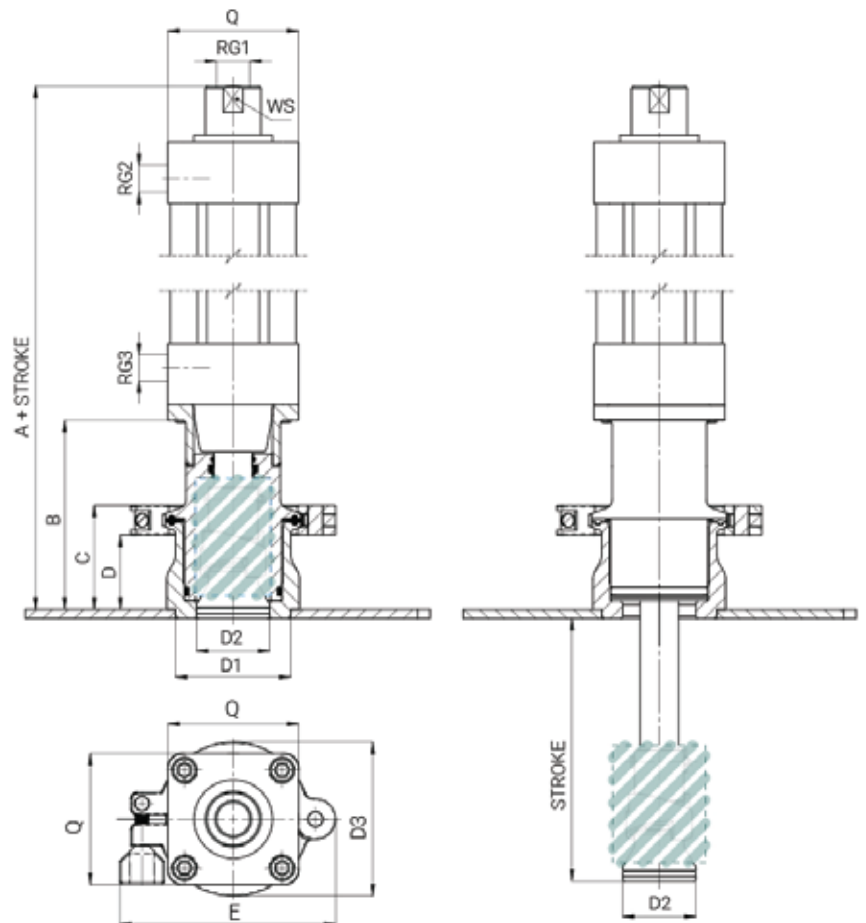

The pneumatic cylinder is equipped with special positioning sensors that generate digital signals when the washing vheads is either in fully extended or fully retracted positions.

UKK

UKK is a retractable tank washing head designed for cleaning small containers, tanks, and pipes. Thanks to its small size and unique design, UKK can be installed flush with the wall and is an ideal cleaning product where traditional systems have difficulty accessing and operating.

Its characteristics make UKK an ideal product in the chemical and pharmaceutical sectors, and the FCMs certification also allows it to be used in the food and beverage sector.

The operation of this cleaning head is simple but highly effective: with an adequate pressure of the feed liquid (between 3 and 7 bar), the nozzle extends by 50 mm and starts the washing action. The flow rate is 35.5 lpm at 3 bar of operation.

UKK is available in AISI 316 steel as a standard material with the possibility of using other metallic materials such as Hastelloy.

MATERIAL: BODY B31 AISI 316L S.S. (HASTELLOY ON REQUEST)
 COMPONENTS B31 AISI 316L S.S.
 E7 VITON
 E1 PTFE TEFLON

LT: 90°

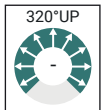

FLOW RATE	15-20-25-30 l/min
TEMPERATURE MAX	90°C
BODY MATERIAL	AISI 316L s.s.
COMPONENT MATERIA	AISI 316L s.s. VITON PTFE TEFLON
PRESSURE RANGE	3/7 bar
CONNECTION	Tri-clamp 1" 1/2
COVERAGE	320° up

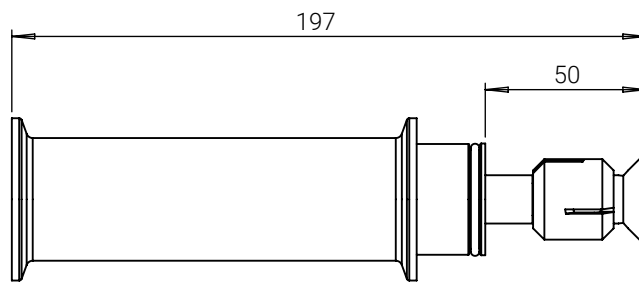

The UKK stroke is 50 mm. The overall length of the standard version is 197 mm.

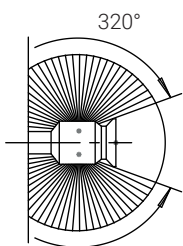

The overall diameter of the UKK is 50,5 mm. The distance between the tri-clamp connections is 126 mm.

UC

UC washing heads are products designed specifically for cleaning pipes. They are generally used with high pressures and exploit the reaction forces created by suitably oriented jets to create a forward push and facilitate cleaning.

These new washing heads, available with two different connection, are generally used with high pressures and exploit the reaction forces created by suitably oriented jets to create a forward push and facilitate cleaning. Therefore, you can clean pipes of different length using only this washing head, without any further installation, saving time and costs.

Different flow rates are available, depending on the connection and on the dimension of the holes of the head.

MATERIAL: AISI 303 STAINLESS STEEL, AISI 304 S.S., AISI 316L S.S., AISI 416 STAINLESS STEEL HARDENED, BRASS

CONNECTION: 1/8" BSPP, 1/4" BSPP

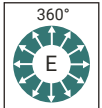

UCA



UCB

CODE	Capacity at different pressures						l/min bar	Ø holes mm
	3,0	10	30	70	90	100		
UCA 1900 zz	1,80	3,10	5,10	8,00	9,10	9,40	0,6	
UCA 2160 zz	3,30	5,70	9,40	14,1	15,9	16,7	0,8	
UCB 2285 zz	5,20	9,5	16,5	25,1	28,5	30,0	1,0	
UCB 2405 zz	7,45	13,6	23,6	36,0	40,7	43,0	1,2	

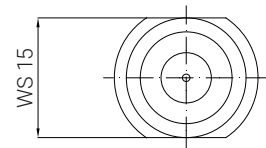
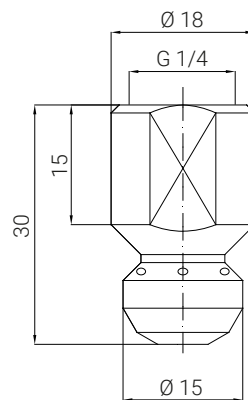
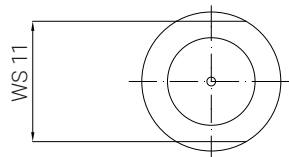
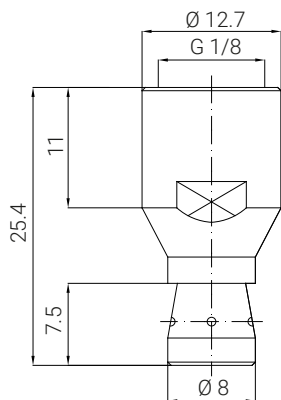

APPLICATIONS OF SPECIAL PRODUCTS

Our sales technicians have complete knowledge of all the industrial applications of our products and a high degree of technical expertise to help you find the best solution for your needs, from planning the production process to improving and optimizing production plants.

We don't just supply products: we also provide integrated services and support. We are available to evaluate requests for products customized according to your specifications or for particular applications.

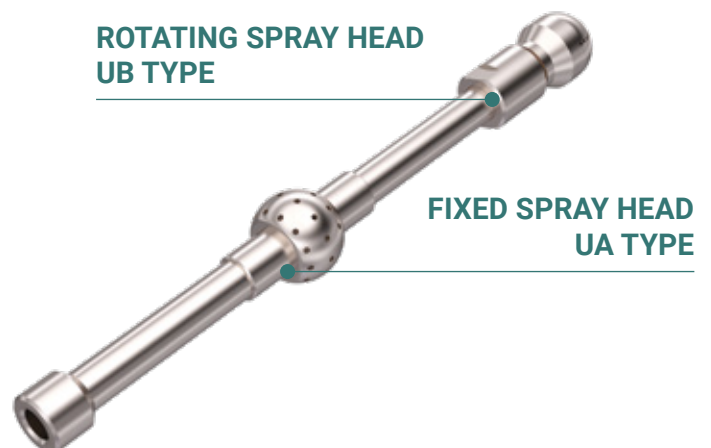



SANITARY PRODUCTS

PNR Italia can certify its products according to the highest hygienic standards. Two necessary certifications allow the use of many PNR Italia equipment in the food, chemical, and pharmaceutical industries:



3-A SANITARY STANDARDS, INC. (3-A SSI)

is an independent, non-profit company that promotes hygienic equipment design for the food, beverage, and pharmaceutical industries.



MOCA

Materials and objects in contact with food

The products designed and certified for the food, chemical, and pharmaceutical industries guarantee a high degree of cleanliness, a better quality of the final product, excellent overall production, and reduced operating costs. Their design minimizes the risk of residues that could compromise the quality of the finished product.



UA3

PNR ITALIA SRL IS AUTHORIZED TO APPLY THE 3-A SYMBOL TO CIP MODELS UA3 XXXX B31 XCX, CONFORMING TO 3-A SANITARY STANDARD 78-01: SPRAY CLEANING DEVICES INTENDED TO REMAIN IN PLACE.

This 3-A Sanitary Standard covers the sanitary aspects of spray cleaning devices attached to stainless steel solution supply tubes intended to remain in place during processing operations and used on storage and processing equipment and machinery for milk, milk products, or other comestibles.

Further information about the UBD S washing head on page 16.

3-A SANITARY STANDARD LOGO

Our warranty



UBD S

THE UBD S SINGLE-AXIS TANK WASHING HEAD IS NOW AVAILABLE WITH MOCA CERTIFICATION.

PNR Italia decided to meet the needs of food and beverage manufacturers by adding the UBD S tank washing head to its vast certified products heads range.

The reaction drive UBD S single-axis tank washing head is made of AISI 316L stainless steel. As it does not require any lubrication, there is no risk of contaminating products with oil or grease, making this device ideal for applications in the pharmaceutical, chemical, and food industries.

Read more about the UBD S washing head on page 16.

WRENCH PLANE MILLING

for 3/8" female threaded connection

CLIP CONNECTION



SUMMARY TABLE

SERIES	CONNECTIONS	MATERIALS	FLOW RATE RANGE (lpm)	OPERATING PRESSURE (bar)	MAX WETTING RADIUS (m)	COVERAGE SPRAY PATTERNS
UBT	threaded (1")	316L s.s.	88,0 ÷ 162	4,0 / 10,0	11,0	360°
UBA	threaded (3/4" or 1-1/2")	316L s.s. PTFE	50,0 ÷ 273	3,0 / 10,0	5,0	360° 270°DOWN 180°DOWN
UBE	threaded (1/2")	316L s.s. PVDF	12,9 ÷ 43,1	2,0 / 16,0	8,0	360°
UBD S	threaded (3/8")	316L s.s.	11,0 ÷ 112,0	2,0 / 12,0	3,0	360°
UBB	threaded (1/2" ÷ 3")	PTFE	21,5 ÷ 1486	1,5 / 3,5	4,0	360° 180°UP 180°DOWN
UBC	threaded (3/8" ÷ 1-1/4"), clip-on, welded	316L s.s.	8,16 ÷ 458	2,0 / 7,0	3,2	360° 180°UP 270°UP 270°DOWN 180°DOWN
UBD	threaded (1/4" ÷ 1-1/2")	316L s.s. Hastelloy C22	29,0 ÷ 321	2,0 / 7,0	4,8	360° 180°UP 180°DOWN
UBD A	threaded (1/4" ÷ 1-1/2")	PTFE PEEK PTFE + 15% graphite	28,6 ÷ 296	2,0 / 6,0	3,0	360° 180°UP 180°DOWN
UBF	threaded (1/2")	316L s.s.	20,0 ÷ 76,0	2,0 / 12,0	1,5	270°DOWN 100°LAT
UBF A	threaded (1/2")	316L s.s. PVDF, PTFE Hastelloy C22	20,0 ÷ 28,8	2,0 / 4,0	2,5	360° 270°DOWN 180°DOWN
UBF S	threaded (1/8")	316L s.s. PTFE	4,50 ÷ 6,40	2,0 / 4,0	0,8	270°DOWN
UBX	threaded (1/4" ÷ 3/4")	316L s.s. PTFE PEEK	16,3 ÷ 99,0	2,0 / 6,0	3,5	360° 270°UP 270°DOWN
UA3	clip-on	316L s.s.	31,6 ÷ 183	1,0 / 2,5	3,5	360° 180°UP 270°UP 180°DOWN
UAB	threaded (1/2")	303 s.s. 316L s.s.	18,0 ÷ 187	2,0 / 5,0	3,5	240°DOWN
UAC	threaded (1/8" ÷ 1-1/4"), clip-on, welded	316L s.s. Hastelloy C267 Titanium Gr2	14,0 ÷ 1412	1,0 / 2,5	3,5	360° 180°UP 270°UP 100°LAT 270°DOWN 180°DOWN
CH	threaded (3/4" ÷ 2")	303 s.s. 316L s.s. Brass	26,0 ÷ 480	1,0 / 10,0	8,0	360° 200°DOWN

CLIP CONNECTION SIZE

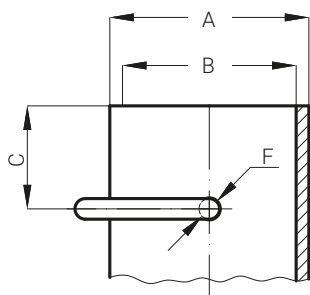

	A	B	C	F
UBC ϕ 25 (UBC xxxx MMxC)	22,0	20,0	9,0	2,5
UBC ϕ 45 (UBC xxxx MMxC)	29,0	25,3	15,0	3,2
UBC ϕ 65 (UBC xxxx MMxD)	44,0	38,4	15,0	3,2
UBD xxxx MMxC	33,0	25,5	9,0	2,5
UBD xxxx MMxD	33,0	25,7	9,0	2,5

There is a number of different dimensions standards relating to clip-on connections on different markets, and between Europe and America. We have therefore identified with our Customers the most commonly requested types and have standardized as follows.

UAC, FIXED SPRAY HEADS

Drawings and sizes are available at pages 5 and 6: these will be the future sizes for every PNR device with clip-on connection, and they are based on DN (nominal diameter), as defined by European standards.

UBC AND UBD, REACTION DRIVE HEADS

For the two above product types clip-on connections will maintain specifications used until present time. The diagram and the table showing the dimensions for the two product types on the different markets is shown below, and covers both European pipe dimensions (last letter of the code: C) and American (last letter of the code: D).

The variety of applications of stainless steel pipes/tubes, welded or seamless, generated several Regulations related to diameters, thicknesses, methods of production and finishing, surface quality, acceptance criteria. Recently, the authorities in charge tried to simplify such regulatory vastness with Standard DIN 11866 dated June 2016 which we report here below for what concerns the dimensional part. The norm is divided into three Ranges:

- Range A: pipe dimensions according to DIN EN 10357 extended by DN6 and DN8 (includes also previous standard DIN 11850);
- Range B: pipe dimensions according to DIN EN ISO 1127 (includes also previous standards DIN 2642 for seamless pipes and DIN 2643 for welded pipes);
- Range C: pipe dimensions according to ASME-BPE 2009.

NOTE

For the dimensioning of its tank washing heads, PNR adopts and uses DIN 11866:2016 as a reference standard, unless otherwise specifically requested by Customers. Standard DIN 11866:2016 does not include all previous Norms and measurement standards. Therefore, in this catalogue, it is possible to find references to dimensions of standards that are not included.

DIN 11866 Range A / 304L - 316L		
De (mm)	Thickness	DN
8,00	1,00	DN6
10,0	1,00	DN8
13,0	1,50	DN10
19,0	1,50	DN15
23,0	1,50	DN20
29,0	1,50	DN25
35,0	1,50	DN32
41,0	1,50	DN40
53,0	1,50	DN50
70,0	1,50	DN65
85,0	2,00	DN80

DIN 11866 Range B / 304L - 316L		
De (mm)	Thickness	DN
10,2	1,60	DN6
13,5	1,60	DN8
17,2	1,60	DN10
21,3	1,60	DN15
26,9	1,60	DN20
33,7	2,00	DN25
42,4	2,00	DN32
48,3	2,00	DN40
60,3	2,00	DN50
76,1	2,00	DN65
88,9	2,30	DN80

DIN 11866 Range C / 304L - 316L			
De (mm)	Thickness	DN	Rif.to
6,35	0,89	DN8	1/4"
9,53	0,89	DN10	3/8"
12,7	1,65	DN15	1/2"
19,05	1,65	DN20	3/4"
25,4	1,65	DN25	1"
38,1	1,65	DN40	1-1/2"
50,8	1,65	DN50	2"
63,5	1,65	DN65	2-1/2"
76,2	1,65	DN80	3"

ABBREVIATIONS

De	EXTERNAL DIAMETER	mm	L, L1	WIDHT	mm	RF	CYLINDRICAL FEM BSP THREAD	poll
Di	INNER DIAMETER	mm	LP	MAX WORKING PRESSURE	bar	RG	CONICAL MALE BSPT THREAD	poll
Dia	ORIFICE DIAMETER	mm	LT	MAX WORKING TEMP.	°C	W	WEIGHT	kg
DN	NOMINAL DIAMETER	--	Q	CAPACITY	l/min	WR	WETTING RADIUS	m
H, H1	HEIGHT	mm						

PRODUCT WARRANTY

PNR products will be replaced or repaired at the option of PNR and free of charges if found defective in manufacturing, labelling and packaging. The above conditions will apply if notice of defects is received by PNR within 30 days from date of product installations or one year from date of shipment.

The cost of above said replacement or repair shall be the exclusive remedy for any breach of any warranty, and PNR shall not be held liable for any damage due to personal injuries or commercial losses coming from product malfunction. It is self-understood that no warranty may apply in case our products have been operated under nonacceptable conditions, like for example (but not limited to):

- Operation at pressures exceeding those shown in catalogue performance table
- Operation with or exposure to liquids containing abrasive particles
- Operation with or exposure to liquids producing a chemical attack on the nozzle material
- Mechanical damages to nozzle orifices, nozzle spray edge or body due to careless handling or assembling.

In all above cases, the customer must accept a nozzle life reduction below life expected, or performance parameters below the values in the catalogue.

The guarantee may be exercised as follows:

1. By sending a precautionary report to PNR on the detected damages. This report can also be sent by email to this address: quality@pnr.it
2. If PNR ascertains that the manufacturing faults are actually subject to the warranty, the product shall have be returned to the manufacturer in its original packaging prior request of authorization to the manufacturer and receipt of manufacturer's written authorization.
3. The rejected goods shall have be returned by the means that PNR will communicate to the customer and the transportation costs of returned merchandise will be entirely borne by the manufacturer.

Our products are manufactured with the best care and according to the latest developments of the technology available. However we cannot assure that every one of our products is perfectly fit for every specific application. The information in this catalogue is provided "as seen" and so we offer no warranty of any kind with respect to the subject matter or accuracy of the information contained herein. This publication may include technical inaccuracies or typographical errors and changes may be periodically made to the information herein without prior notice.

CERTIFICATIONS



3-A

PNR Italia srl is authorized to use the 3-A Symbol to the tank washing head code UA3 xxxx B31 xCx, conforming to 3-A Sanitary Standard 78-01 (Spray Cleaning Devices Intended to Remain In Place).



ATEX

Single-axis rotary spray balls UBA, UBC, UBD, UBF, UBF-A, UBF-S are available in ATEX ("Atmosphères explosibles") version, in conformity with European Community Directive 2014/34/EU that determine compliance with the essential safety requirements for equipment and protection systems intended for use in potentially explosive atmospheres. ATEX version is available, on request, for tank washing heads made of AISI 316L s.s. or Hastelloy C22.



MOCA

Tank washing heads produced exclusively in AISI 316L s.s. and / or pure PTFE are available in MOCA version ("Materials and objects in contact with food"), in accordance with the Framework Regulation 1935/2004 and Regulation 2023/2006, which establish the criteria of traceability and processing of materials.

The MOCA version is available on customer's request for the washing heads produced in AISI 316L s.s., pure PTFE or with both materials.



PNR ITALIA HA CERTIFICATO
IL SUO SISTEMA DI QUALITÀ CON DNV
SECONDO LE NORME ISO 9001/2015

**COMPANY WITH
QUALITY SYSTEM**

CERTIFIED BY DNV GL

ISO 9001:2015

A GLOBAL PRESENCE ALL OVER THE WORLD.

CTG LSEN - ©PNR Italia, all rights reserved

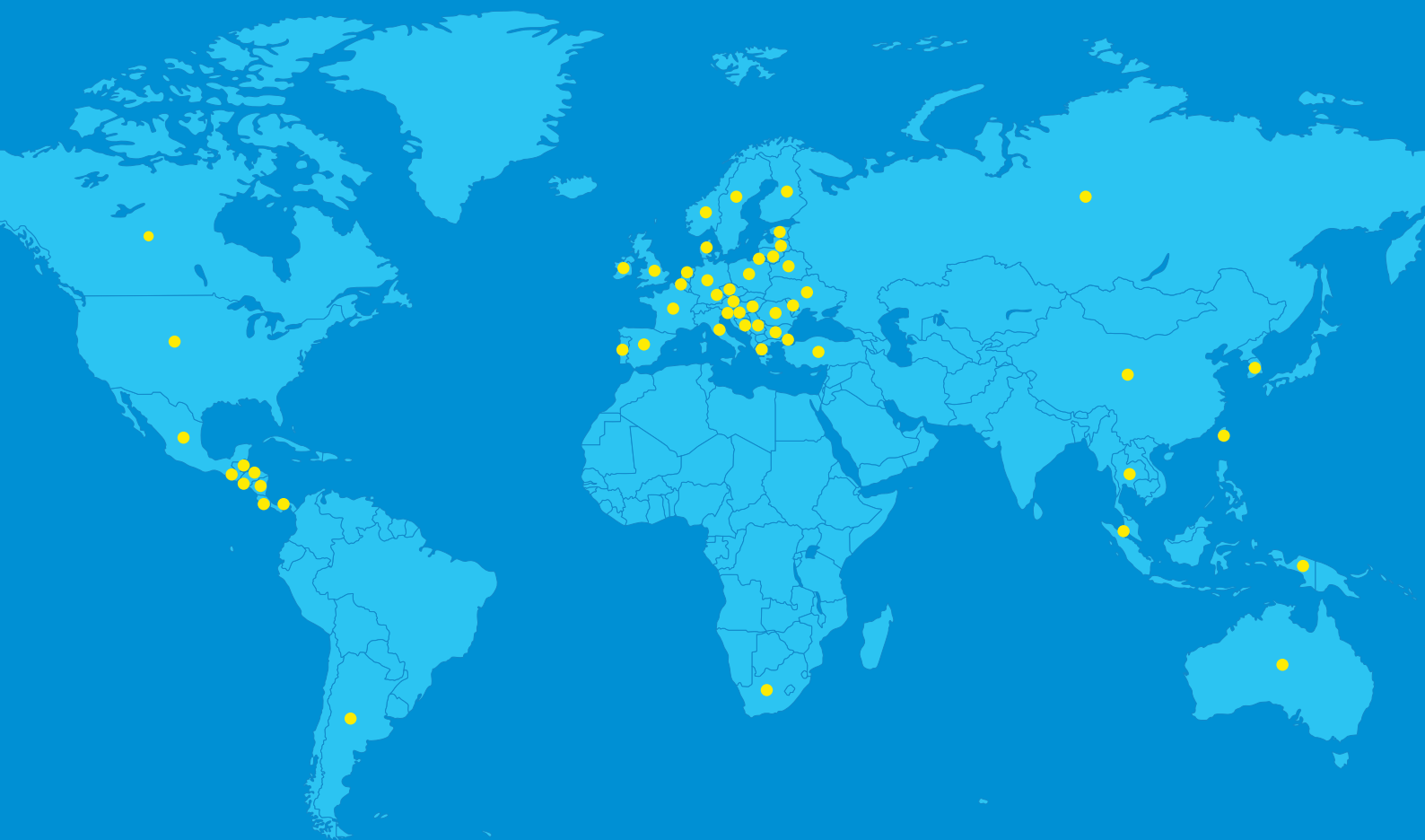

HEADQUARTERS:

PNR Italia srl Via Gandini 2 27058 Voghera (PV) Italy

☎ +39 0383 344 611 ✉ Email info@pnr.it

For further information, visit www.pnr.eu

